



**finder**<sup>®</sup>

SWITCH TO THE FUTURE

## USER'S MANUAL 7M

SERIES OF THREE-PHASE METERS 7M.38.8.400.XXXX:

7M.38.8.400.0112

7M.38.8.400.0212

7M.38.8.400.0312

# THREE-PHASE ELECTRICAL ENERGY METER

## USER AND INSTALLATION MANUAL



## SECURITY ADVICES AND WARNINGS

Please read this chapter carefully and examine the equipment carefully for potential damages which might arise during transport and to become familiar with it before continue to install, energize and work with a three-phase energy meter 7M.38.8.400.xxxx.

This chapter deals with important information and warnings that should be considered for safe installation and handling with a device in order to assure its correct use and continuous operation.

Everyone using the product should become familiar with the contents of chapter »Security Advices and Warnings«.

If equipment is used in a manner not specified by the manufacturer, the protection provided by the equipment may be impaired.

### PLEASE NOTE

This booklet contains instructions for installation and use of three-phase energy meter 7M.38.8.400.xxxx.

Installation and use of a device also includes handling with dangerous currents and voltages therefore should be installed, operated, serviced and maintained by qualified personnel only. FINDER S.p.A assumes no responsibility in connection with installation and use of the product.





If there is any doubt regarding installation and use of the system in which the device is used for measuring or supervision, please contact a person who is responsible for installation of such system.



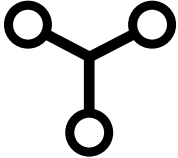
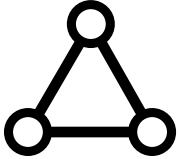
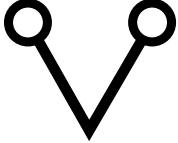

### BEFORE SWITCHING THE DEVICE ON

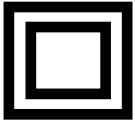
Check the following before switching on the device:

- Nominal voltage
- Terminals integrity
- Protection fuse for voltage inputs (recommended maximal external fuse size is 80 A)
- External switch or circuit breaker must be included in the installation for disconnection of the devices' power supply. It must be suitably located and properly marked for reliable disconnection of the device when needed
- Proper connection and voltage level of I/O module

## USED SYMBOLS ON DEVICES' HOUSING AND LABELS

SYMBOL	EXPLANATION
	Three-phase 4-wire connection (3L+N)
	Three-phase 3-wire 3 system connection (3L)
	Three-phase 3-wire 2 system connection (3L-2I Aron connection)
	Single-phase connection (L+N).
	<b>WARNING</b> Indicates situations where careful reading of this manual is required and following requested steps to avoid potential injury is advised
	Double insulation in compliance with the EN 61010–1: 2010 standard
	NFC communication
	IR - infrared (optical) communication

SYMBOL	EXPLANATION
	Modbus communication
	M-Bus communication
	Compliance of the product with directive 2002/96/EC, as first priority, the prevention of waste electrical and electronic equipment (WEEE), and in addition, the reuse, recycling and other forms of recovery of such wastes so as to reduce the disposal of waste. It also seeks to improve the environmental performance of all operators involved in the life cycle of electrical and electronic equipment
	Compliance of the product with European CE directives

## DISPOSAL

It is strongly recommended that electrical and electronic equipment (WEEE) is not deposited as municipal waste.

The manufacturer or provider shall take waste electrical and electronic equipment free of charge.

The complete procedure after lifetime should comply with the Directive 2002/96/EC about restriction on the use of certain hazardous substances in electrical and electronic equipment.

# TABLE OF CONTENTS

<b>BASIC DESCRIPTION AND OPERATION</b>	page - 6
INTRODUCTION	page - 6
DESCRIPTION OF THE DEVICE	page - 6
THREE-PHASE ENERGY METERS APPLICATION	page - 7
MAIN FEATURES	page - 7
TYPE DIFFERENCES	page - 8
<b>CONNECTION</b>	page - 9
MOUNTING	page - 9
ELECTRICAL CONNECTION	page - 10
<b>FIRST STEPS</b>	page - 14
KEYBOARD NAVIGATION	page - 14
LCD USER INTERFACE	page - 14
CALIBRATION AND SETTING PARAMETERS	page - 26
<b>TECHNICAL DATA</b>	page - 26
ACCURACY	page - 26
MECHANICAL CHARACTERISTICS OF INPUT	page - 27
ELECTRICAL CHARACTERISTICS OF INPUT	page - 28
SAFETY AND AMBIENT CONDITIONS	page - 29
EU DIRECTIVES CONFORMITY	page - 30
DIMENSIONS	page - 30
<b>ABBREVIATION/GLOSSARY</b>	page - 31
<b>APPENDICES</b>	page - 32
APPENDIX A: MODBUS - COMMUNICATION PROTOCOL	page - 32
APPENDIX B: M-BUS	page - 54
APPENDIX C: EQUATIONS	page - 57

## BASIC DESCRIPTION AND OPERATION

The following chapter presents basic information about a three-phase energy meter 7M.38.8.400.xxxx required to understand its purpose, applicability and basic features connected to its operation. In this chapter you will find:

- INTRODUCTION
- DESCRIPTION OF THE DEVICE
- THREE-PHASE ENERGY METERS APPLICATION
- MAIN FEATURES
- TYPE DIFFERENCES

### INTRODUCTION

Regarding the options of a three phase energy meter, different chapters should be considered since it might vary in functionality.

### TABLES

Supported functions and measurements are listed in tables. Symbols in tables indicate support of enabled functions for different connection schemes. Additionally a legend is placed below table of used symbols. Meaning of symbols is:

- Function is supported
- ✗ Function is not supported
- Symbol meaning varies and is described in the legend below the table

### DESCRIPTION OF THE DEVICE

The three-phase energy meters 7M.38.8.400.xxxx are intended for energy measurements in three-phase electrical power network and can be used in residential, industrial and utility applications. Meters measure energy directly in 3-wire and 4-wire networks according to the principle of fast sampling of voltage and current signals.

A built-in microprocessor calculates active/reactive/apparent power and energy, current, voltage, frequency, power factor, power angle and frequency (for each phase and total sum) from the measured signals. This smart meter can also perform basic harmonic analysis (THDU, THDI). This enables quick overview of harmonic distortion either coming from a network or generated by the load. Microprocessor also controls LCD, LED, IR communication and optional extensions.

A capacitive touch button on the front of the energy meter enables access to switch between measurements and settings in the menu. Connecting terminals can be sealed up against non-authorized access with protection covers.

The meters are built to be fastened according to EN 60715 standard.

Figure 1: Appearance of three-phase electric energy meter 7M.38.8.400.xxxx



- |     |   |
|-----|---|
| 1   | Current terminals – to load   |
| 2   | AUX terminals (options):  |
|     | • RS485 (MODBus)  |
|     | • M-BUS   |
|     | • PULSE INPUT AND OUTPUT (SO <sub>1,2</sub> )   |
| 3   | NFC   |
| 4   | Information display   |
| 5   | DIN-Rail fitting  |
| 6   | IR communication port – ON SIDE   |
| 7   | LED indicator   |
| 8   | Cap touch   |
| 9   | Tariff clock input  |
| 10  | Neutral input   |
| 11  | Current terminal – source (max 80 A)  |
| LCD | Display type: Matrix (128 x 64)<br>Illumination: white (normal operation)<br>red (alarm indication) |
| LED | Colour: red<br>Pulse rate: 1000 imp/kWh<br>LED on: no load indication                               |

## THREE-PHASE ENERGY METERS APPLICATION

Energy meters have built-in optical (IR) communication port on the side.

It can be used for controlling Bistable switch – or in combination with SG smart gateway.

It can be used for direct communication with a PC to change settings of devices without any communication installed.

Optional the meter can be equipped with the following communications:

- **RS485** serial communication with the MODBUS protocol
- **M-BUS** serial communication

Communication modules enables data transmission and thus connection of the measuring places into the network for the control and management with energy.

Besides of communication modules, there are also tariff input and built-in pulse output.

Tariff input provides measurement of two tariffs for selected energy registers.

Pulse output S01,2 is sending data to the devices for checking and monitoring consumed energy.

Energy meters are equipped with NFC communication for easy setting and downloading data via mobile app.

NFC communication is implemented for parametrization as well as for reading data (e.g. counters, measurements, etc.) from the smart meter. Special application available from our internet site has to be used to perform such operations.

## MAIN FEATURES

- Three-phase direct connected DIN-rail mounting meters up to maximum current 80 A ( $I_{max}$ )
- MID approval
- Class 1 for active energy according to EN 62053-21 and B according to EN 50470-3
- Class 2 for reactive energy according to IEC 62053-23
- Bidirectional energy measurement (import/export)
- Temperature range climatic condition as indoor meter according EN 50470
- Display segment Matrix LCD
- Multifunctional front red LED
- IR serial communication
- Measurement of:
  - o power (active, reactive, apparent) and energy (each phase and total)
  - o voltage (each phase)
  - o current (each phase)
  - o phase to phase voltage
  - o phase to phase angle
  - o frequency
  - o power factor (each phase and total)
  - o power angle (each phase and total)
  - o active tariff (option)
  - o THD of voltage
  - o THD of current
- 2nd multifunction pulse output (valid only for 7M.38.8.400.0112)
- RS485 Serial communication (valid only for 7M.38.8.400.0212)
- NFC (option) enables an easy setting and downloading meter data via mobile app
- M-bus Serial communication (valid only for 7M.38.8.400.0312)
- Tariff input (230 V AC)
- Tariff management (up to 6 tariffs manageable via communication)
- -25°C - 70°C ambient operation temperature
- 3-DIN rail width mounting according to EN 60715
- Sealable terminal cover



## TYPE DIFFERENCES

Different type differ on functionality and equipment as shown in the following table.

General hardware features	7M.38.8.400.0112	7M.38.8.400.0212	7M.38.8.400.0312
MID approval	●	●	●
Pulse output S0 <sub>1</sub>	●	●	●
Pulse output S0 <sub>2</sub>	●	–	–
Tariff input	●	●	●
70°C display	●	●	●
Infrared (optical) communication - IR	●	●	●
MODBUS comm. Protocol RS485	–	●	–
General software features	7M.38.8.400.0112	7M.38.8.400.0212	7M.38.8.400.0312
MODBUS comm. Protocol (IR)	–	●	–
M-bus serial comm.	–	–	●
NFC communication	●	●	●

**Table 1:** General hardware and software features of different types of meters

## CONNECTION

This chapter deals with the instructions for three-phase electrical energy meter 7M.38.8.400.xxxx connection.

Both the use and connection of the device includes handling with dangerous currents and voltages.

Connection shall therefore be performed **ONLY** by a qualified person using an appropriate equipment. FINDER S.p.A. does not take any responsibility regarding the use and connection.

If any doubt occurs regarding connection and use in the system which device is intended for, please contact a person who is responsible for such installations.

In this chapter you will find:

- MOUNTING
- ELECTRICAL CONNECTION

### MOUNTING

Three-phase electrical energy meter 7M.38.8.400.xxxx is intended for DIN-rail mounting.

In case of using the stranded wire, the ferrule must be attached before the mounting.

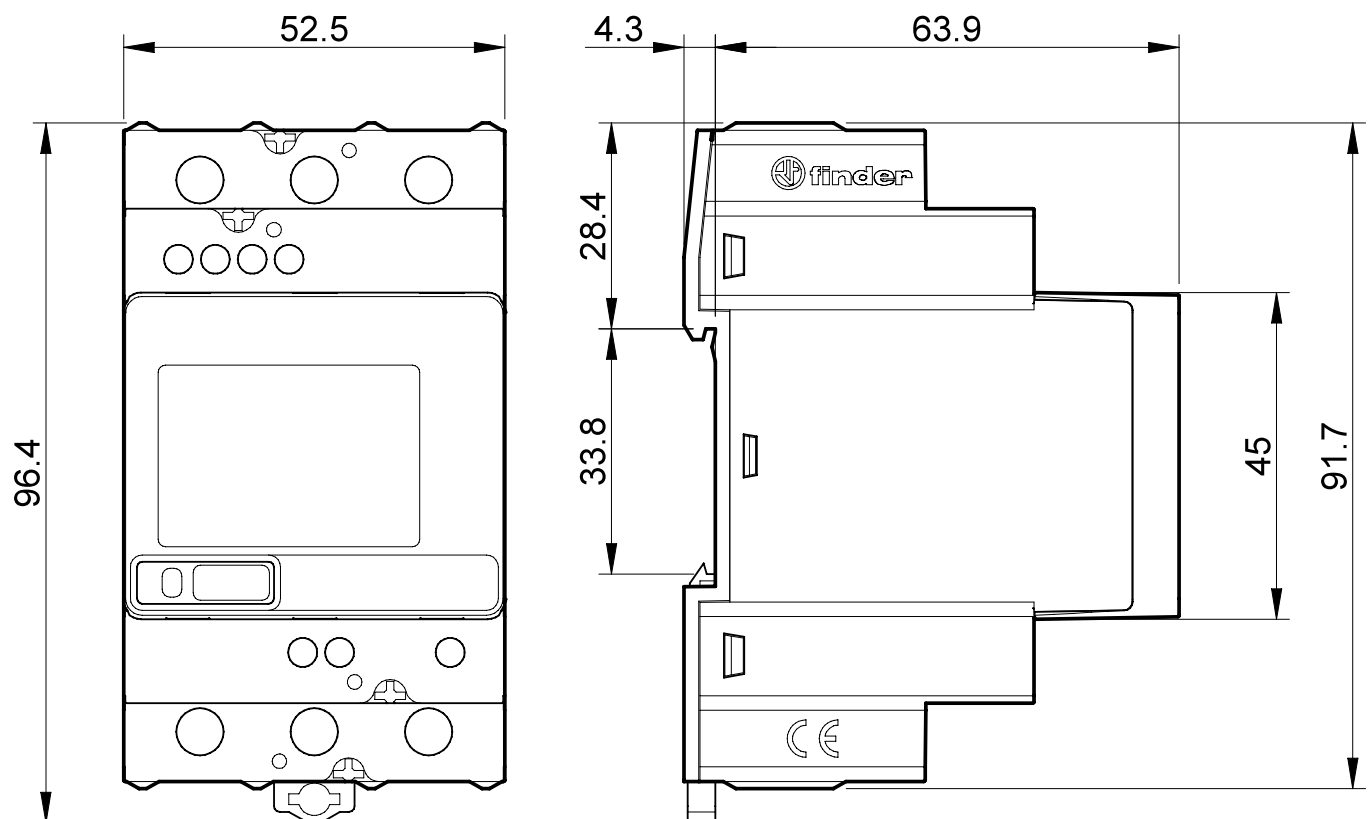

Figure 2: Dimensional drawing and rear connection terminals position

## ELECTRICAL CONNECTION

### WARNING

Wrong or incomplete connection of voltage or other terminals can cause non-operation or damage to the device.

Installation must be carried out and inspected by a specialist or under his supervision.

When working on the meter, switch off the mains voltage! It is recommended to use 3x80 A fuse for the line protection.

Meter is used for direct connection into the three-phase four-wire or three-wire networks.

It can be used also in single-phase network, connected in the phase L3. Three-wire 2 system connection network measures only phase to phase values (phase values are not available).

After electrical installation for MID approved meters the installation should be also set and confirmed in software.

Until installation confirmation warning Installation not set is displayed on LCD.

### PLEASE NOTE

Setting of installation can be done just once, so take care to confirm the connection which fits the required connection and required use.

Recommended installation:

- 1 Mounting to DIN rail according to DIN EN60715
- 2 Power contacts:
  - Power contacts capacity 2.5 mm<sup>2</sup> – 25 mm<sup>2</sup>
  - Connection screws M5
  - Max torque 3.5 Nm
- 3 Auxiliary terminals:
  - Auxiliary terminals contact capacity 0.05 mm<sup>2</sup> – 1.5 mm<sup>2</sup>
  - Auxiliary terminals screws M3
  - Max torque 0.6 Nm

#### Mark Meaning

L<sub>1,2,3</sub> Line input

N Neutral input

**Table 2:** Marks used on wire connection diagrams

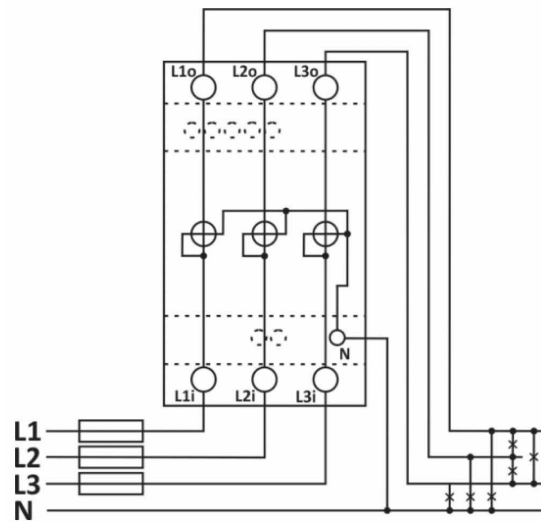

Figure 3: Three-phase 4-wire connection diagram (3L+N)

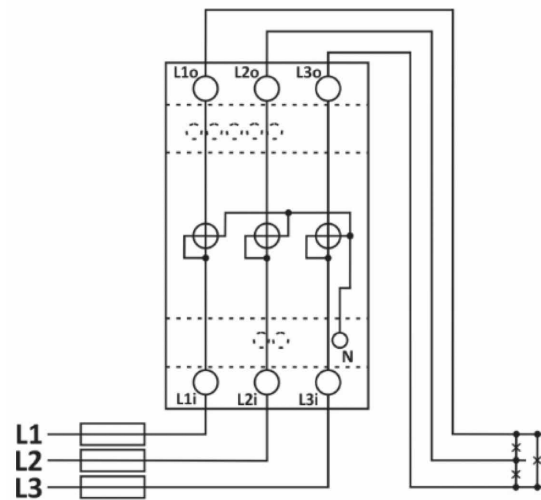

Figure 4: Three-phase 3-wire 3 system connection diagram (3L)

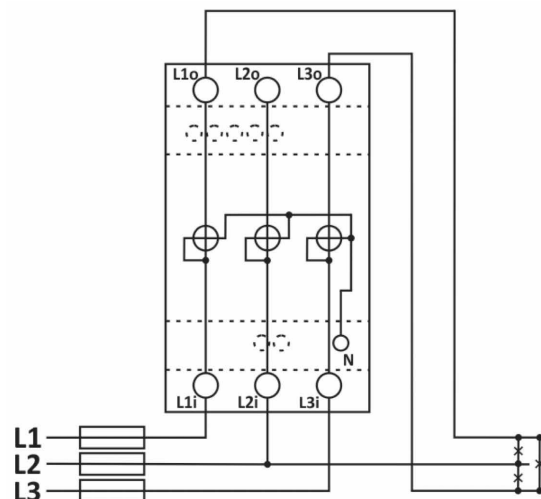

Figure 5: Three-phase 3-wire 2 system connection diagram (3L-2I)

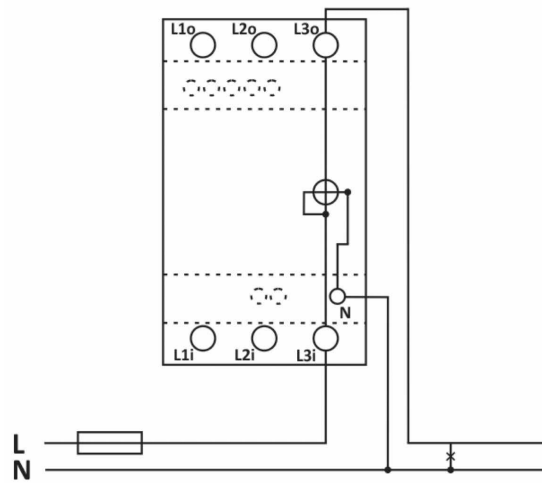

Figure 6: Single-phase connection diagram L+N

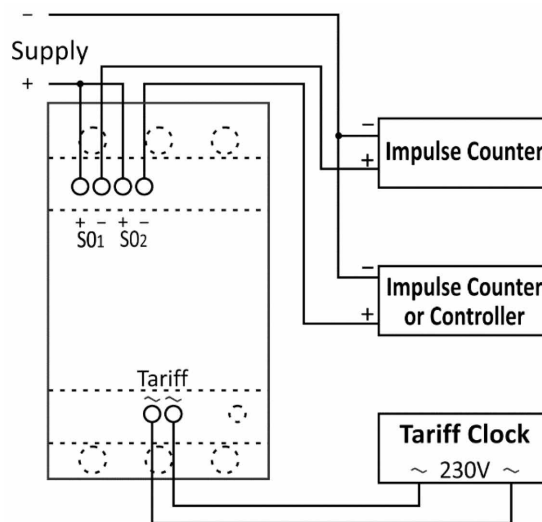

Figure 7: Connection diagram of S0 output, impulse counter, impulse counter or controller and tariff clock

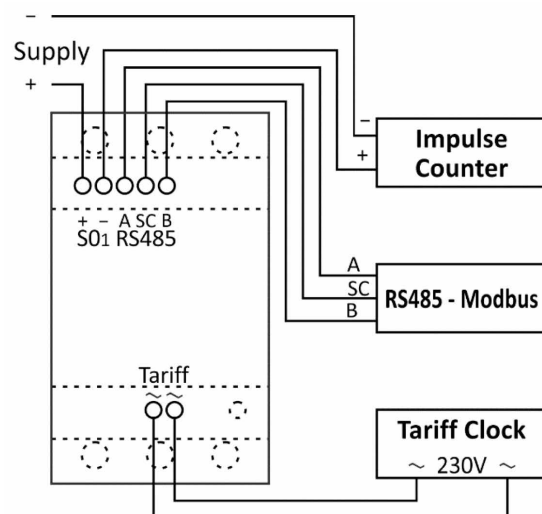

Figure 8: Connection diagram of S0 output, impulse counter, RS485 - Modbus and tariff clock

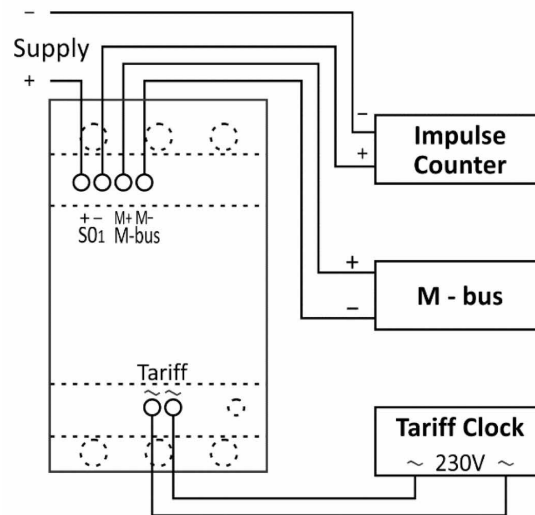

Figure 9: Connection diagram of S0 output, impulse counter, M - bus and tariff clock

## AUXILIARY CIRCUIT CONNECTION

For communication with outside world multiple manners are used:

- **IR communication module (option)** using MODBUS protocol. It can be used for setting and testing the meter using USB adapter.
- **S01,2 output module** is used for counting number of pulses depending on consumed energy.
- **RS485 (option)** communication module is galvanic isolated from meter main circuit. It enables setting the meter, data readout in the network and tariff setting.
- **M-BUS (option)** communication module is galvanic isolated from meter main circuit. It enables setting the meter, data readout in the network and tariff setting.
- **NFC (option)** enables an easy setting and downloading meter data via mobile app.
- **Tariff input (option)** module is used to set active tariff.
- **LED diode** is used for indication of no-load condition and test output proportional to measured active energy. It can be also switched to reactive energy for test purpose using IR communication or cap touch.
- **A capacitive touch button** enables access to switch between measurements and settings in the menu.

AUXILIARY TERMINAL			
Pulse output (S01, S02)	+	-	
Tariff input	~	~	
M-bus (COM)	M+	M-	
RS485 (COM)	A	*SC	B

\*It is intended to be used for shielding for RS485

Table 3: Survey of auxiliary circuit connection

## PLEASE NOTE

Check markings on the side of the meter to check what modules are built in.

## FIRST STEPS

Programming a three-phase electrical energy meter 7M.38.8.400.xxxx is very transparent and user friendly. Numerous settings are organized in groups according to their functionality. In this chapter you will find basic programming steps:

- KEYBOARD NAVIGATION
- LCD USER INTERFACE
- CALIBRATION AND SETTING PARAMETERS
- FREEZE COUNTERS

### KEYBOARD NAVIGATION

The capacitive touch (symbol below) is used for shifting between screens, for selecting the specific segment of the menu and for confirming the settings. Press the capacitive touch (short-touch) to move forward between the screens. Long-touch (approximately 3 seconds) is used to confirm the selection, to sett the next digit, or to enter the sub-menu. Very-long-touch (approximately 5 seconds) considers the function ESC (during the parameter setting the screen goes back to the explicit parameter in the other cases the LCD returns in the initial cycling mode).

If the screen backlight is off, the first touch turns on the backlight, then the long-touch to view the main menu. If the lock of the capacitive touch is available, to activate it, a very long-touch is needed.



Figure 10: The symbol of capacitive touch

### LCD USER INTERFACE

#### LCD DISPLAY AT START UP

SN: serial number  
 MID: Version and CRC of Part 2  
 FUN: Version and CRC of Part 2  
 HW: Hardware version; m.: CRC of phase measuring modules (high, low)  
 Run: Operational time (days hours minutes)

```
SN : X0000100
M: 0.68 E65BA1DB
F: 0.68 5F351014
H: A m.00005AB6
Run: 1d 5:25
```

After the electrical connection, the display shows an info screen (picture on top) for two seconds. The following is holding page (default setting) of last observed measurement on the screen.

**Installation  
Not set**

Measurements consist of energy counters and other actual measured values. The MID approved meter shows a warning screen (picture on the right) Installation Not set every 5 seconds if the installation of connection mode is not set yet.

Besides the holding page of measurement, one can enter the display menu structure by using a long touch. If the capacitive touch is not pressed for more than 90 seconds, that specific measurement screen will be shown again.

This is also in case of a powerdown.

Cycling page function is a function that cycles measurements on the screen regarding the period that is defined in settings (for more details see chapter Settings, Device settings, General settings, Display). If the capacitive touch is not pressed for more than 90 seconds, the cycling of measurements automatically begins again. The explicit settings can be changed through the Setting menu (for more details see chapter Display of device setting), Fi-MIS software or mobile app using NFC.

### PLEASE NOTE

All settings that are performed can be subsequently changed via Fi-MIS by means of communication

### PLEASE NOTE

The meter can be set to Test measuring mode which displays energy registers with better resolution. The test mode is used for test purposes during type testing and test of meter constant during initial verification. After power off meter automatically goes back to normal operation.

## CAPACITIVE TOUCH SELF CALIBRATION PROCESS

In a reported fixed 64s interval the average, minimum and maximum value of the capacitive touch sensor is calculated. If the conditions are stable (without interruptions) then the average value of the capacitive touch sensor is used as a reference value.

If the new reference value deviates sufficiently from the permanently stored value, it is permanently saved.

Permanently stored value is used when the power is turned on.

## ENERGY COUNTERS

There are two sets of energy registers – four non-resettable registers which can be assigned for active energy (MID approved), reactive energy (national approval) or apparent energy (no approval).

The meter with MID approval should have at least one register with active energy measurement.

There are additional 16 energy registers which can be parameterised by the user regarding type of energy, active quadrants, direction of counting and tariff and they can also be resetted using MODBUS command or cap touch.

On the LCD up to two energy counters are displayed.

There is the lock sign for the fixed legally relevant non-resettable counters, the counter designation, the sign of currently active register, an additional code and the unit.

For the code the user can choose between the OBIS code or letter description code (the latter is the default). The 9-digit numerical number shows the value of the energy. The decimal dot is fixed and resolution is fixed to 100 Wh. The screen is displayed for the pre-set cyclic period.

### PLEASE NOTE

In compliance with the MID directive, where the final test is done before selling the products, it may happen that the MID energy meters show a low energy consumption even if they are new.

This can only happen to relatively small percentage of meters for each production lot and the highest value should be around 6 kWh for the Active Imported Energy



Legally relevant non-resettable registers are designated with letters 1 to 4 after the lock sign, while legally non-relevant resettable registers are designated with 01 to 16. The code is specified in table 4 and table 5.

REGISTER DESCRIPTION E1 TO E4	OBIS CODE	LETTER DESCRIPTION CODE
Active energy Q1+Q4 – all tariffs	1.8.0	A.I.0
Active energy Q2+Q3 – all tariffs	2.8.0	A.E.0
Active absolute energy– all tariffs (Abs(Q1+Q4) + abs(Q2+Q3))	15.8.0	A.A.0
Reactive energy – Q1+Q2 - all tariffs	3.8.0	r.I.0
Reactive energy – Q3+Q4 - all tariffs	4.8.0	r.E.0
Reactive absolute energy– all tariffs	95.8.0 (manufacturer specification)	r.A.0
Apparent absolute energy-all tariffs	9.8.0	S.A.0

Table 4: OBIS code and letter description code for E1 to E4

REGISTER DESCRIPTION C1 TO C16	OBIS CODE	LETTER DESCRIPTION CODE
Active energy Q1+Q4 – all tariffs	1.8.0	A.I.0
Active energy Q1+Q4 – tariff 1 to 6	1.8.1 to 1.8.6	A.I.1 to A.I.6
All energy types – tariff 1 to 6	x.x.1 to x.x.6	x.x.1.to x.x.6
All energy types – mixed tariffs (example tariff 1 and tariff 2)	x.x.9	x.x
Active energy Q2+Q3 – all tariffs	2.8.0	A.E.0
free	15.8.0	A.A.0
Active energy (signed)– all tariffs (Abs(Q1+Q4) – abs(Q2+Q3))	16.8.0	A.b.0
Active energy Q1– all tariffs	17.8.0	A. .0
Active energy Q2– all tariffs	18.8.0	A. .0
Active energy Q3– all tariffs	19.8.0	A. .0
Active energy Q4– all tariffs	20.8.0	A. .0
Reactive energy – Q1+Q2 - all tariffs	3.8.0	r.I.0
Reactive energy – Q3+Q4 - all tariffs	4.8.0	r.E.0
Reactive energy – Q1 - all tariffs	5.8.0	r. .0
Reactive energy – Q2 - all tariffs	6.8.0	r. .0
Reactive energy – Q3 - all tariffs	7.8.0	r. .0
Reactive energy – Q4 - all tariffs	8.8.0	r. .0
Reactive absolute energy– all tariffs	95.8.0 (manufacturer specification)	r.A.0
Apparent absolute energy-all tariffs	9.8.0	S.A.0
Apparent energy –Q1+Q4 – all tariffs	9.8.0	S.I.0
Apparent energy – Q2+Q3 – all tariffs	10.8.0	S.E.0
Other unspecified custom setting regarding power, quadrants	0.0.y y (0,1,2,3,4,9)	x. .y x x (A,r,S), y (0,1,2,3,4,» «)

Table 5: OBIS code and letter description code for C1 to C16

## INITIAL DISPLAY MENU STRUCTURE

The following is a main menu divided into several sub-menus (ESC, Measurements, Info, Settings, Resets, Installation).

### MAIN MENU:

- ESC
- MEASUREMENTS
- INFO
- SETTINGS
- RESETS
- INSTALLATION

www.findernet.com / Temperature 27 °C

## ESC

```

Main menu          Ⓞ
ESC
Measurements
Info
Settings
Resets
www.findernet.com
  
```

Long-touch ESC, the screen holds on to the chosen measurement on default mode. The mode could be changed in Fi-MIS software, to counter n1 or to cycling mode (cycling between measurements). Short-touch to shift between sub-menus.

## DISPLAY OF DEVICE MEASUREMENTS

```

Main menu          Ⓞ
ESC
Measurements
Info
Settings
Resets
www.findernet.com
  
```

Short-touch Measurements, the sub-menu is entered (ESC, Present values, Limits). Long-touch ESC to return to the main menu.

### MEASUREMENTS

```

ESC
Present values
<= Main menu
  
```

## PRESENT VALUES

### PRESENT VALUES

```

ESC
Voltage
Current
Power
PF & Power angle
Frequency
Energy
THD
Custom
Overview
<= Measurements
  
```

Long-touch Present values, the sub-menu is entered (ESC, Voltage, Current, Power, PF & Power angle, Frequency, Energy, THD, Custom, Overview). Long-touch ESC to return to the measurements menu. Short-touch to shift between sub-menus.

## VOLTAGE

Present values
ESC
<b>Voltage</b>
Current
Power
PF & Power angle
↔ Measurements

Long-touch Voltage to observe the phase voltage, phase to phase voltage, voltage angle, average values of phase voltage, and average values of phase to phase voltage.

Phase voltage 1,2,3	Phase to phase voltage	Voltage angle	Averages
18.5 <sub>9</sub> V U1	0.0 <sub>0</sub> V U12	+0.0 <sub>0</sub> ° ϕ12	82.7 <sub>7</sub> V U <sub>λ</sub> 153.1 <sub>0</sub> V U <sub>Δ</sub>
18.6 <sub>0</sub> V U2	226.4 <sub>4</sub> V U23	+0.0 <sub>0</sub> ° ϕ23	
234.5 <sub>1</sub> V U3	226.4 <sub>1</sub> V U31	+0.0 <sub>0</sub> ° ϕ31	

## CURRENT

Present values
ESC
Voltage
<b>Current</b>
Power
PF & Power angle
↔ Measurements

Long-touch Current to observe the phase current, and average current.

Phase current	Average current
--- A I1	0.000 <sub>0</sub> A I <sub>avg</sub> 0.000 <sub>0</sub> A I
--- A I2	
0.000 <sub>0</sub> A I3	

## POWER

Present values
Voltage
Current
<b>Power</b>
PF & Power angle
Frequency
↔ Measurements

Long-touch Power to observe the power (active, reactive, apparent), phase power (active, reactive, apparent).

Power	Phase active power	Phase reactive power	Phase apparent power
0.0 <sub>0</sub> W P	--- W P1	--- var Q1	--- var Q1
0.0 <sub>0</sub> var Q	--- W P2	--- var Q2	--- var Q2
0.0 <sub>0</sub> VA S	0.0 <sub>0</sub> W P3	0.0 <sub>0</sub> var Q3	0.0 <sub>0</sub> var Q3

## PF & POWER ANGLE

Present values
Current
Power
<b>PF &amp; Power angle</b>
Frequency
Energy
↔ Measurements

Long-touch PF & Power angle to observe the power factor and power angle, phase power factor and phase power angle.

Power factor, power angle	Phase power factor	Phase power angle
+1.000 <sub>3</sub> PF	--- PF1	--- ° ϕ1
+0.0 <sub>0</sub> ° ϕ	--- PF2	--- ° ϕ2
	+1.000 <sub>3</sub> PF3	+0.0 <sub>0</sub> ° ϕ3

## FREQUENCY

Present values
Power
PF & Power angle
<b>Frequency</b>
Energy
THD
↩ Measurements

50.003<sub>5</sub> f<sub>Hz</sub>

## ENERGY

Present values
PF & Power angle
Frequency
<b>Energy</b>
THD
Custom
↩ Measurements

Long- touch Energy to observe the measured energy.

Two different types of energy registers are shown (resettable and non-resettable).

Disabled energy counters are not shown on the screen.

The resettable energy counter (Non-MID meters) can be reset, while the non-resettable (the symbol of lock representing it) has been measuring the quantity continuously.

The resettable energy counters enable to set the value of measured energy (see chapter Settings, energy, counters).

The energy counter you reset starts to re-measure the value from the zero

Measured energy		Measured energy		Measured energy (resettable)	
♣1	A.I.O kWh 1.2	♣3	R.I.O kvarh 0.8	01	A.I.O kWh 1.2
♣2	A.E.O kWh 0.5	♣4	R.E.O kvarh 0.5	02	R.I.O kvarh 0.8
Measured energy (resettable)		Measured energy (resettable)		Measured energy (resettable)	
03	S.A.O kVAh 2.6	05	A.E.O kWh 0.5	07	S.A.O kVAh 2.6
04	A.I.O kWh 1.2	06	R.E.O kvarh 0.5	08	A.E.O kWh 0.5

## THD

Present values
Frequency
Energy
<b>THD</b>
Custom
Overview
↩ Measurements

Long- touch THD to observe the total harmonic distortion of current and voltage.

THD of current		THD of voltage	
0.0 <sub>0</sub>	11% %THD	1.9 <sub>9</sub>	U1% %THD
0.0 <sub>0</sub>	12% %THD	1.9 <sub>9</sub>	U2% %THD
0.0 <sub>0</sub>	13% %THD	1.9 <sub>6</sub>	U3% %THD

## CUSTOM

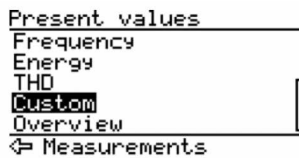

Long- touch Custom to observe the measurements of phase one, measurements of phase two, measurements of phase three and custom measurements.

Phase 1	Phase 2	Phase 3	Custom
17.8 <sub>2</sub> V U1 --- A I1 --- W P1	17.8 <sub>5</sub> V U2 --- A I2 --- W P2	233.8 <sub>4</sub> V U3 0.000 <sub>0</sub> A I3 0.0 <sub>0</sub> W P3	U1 17.87 V I1 0.0000 A P1 0.00 W + U2 17.88 V I2 0.0000 A

## OVERVIEW

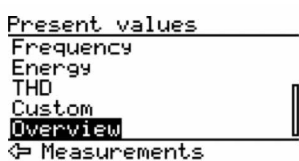

Long- touch Overview to observe the custom screens.

Values of measurements

U <sub>A</sub>	84.14 V	P	+0.00
I	16.98 V	P1	+0.00
U <sub>B</sub>	16.98 V	P2	+0.00
U <sub>C</sub>	231.84 V	P3	+0.00
I <sub>A</sub>	0.0000 A	Q	+0.00
I <sub>1</sub>	0.0000 A	Q1	+0.00
U <sub>0</sub>	0.0000 A	Q2	+0.00
U <sub>0</sub>	0.0000 A	Q3	+0.00

U <sub>0</sub>	151.79 V	49.984 Hz
I <sub>0</sub>	0.00 V	φ +0.00°
U <sub>03</sub>	227.71 V	φ +0.00°
U <sub>01</sub>	227.68 V	φ +0.00°
PF	+1.000L	φ +0.00°
PF1	+1.000L	φ +0.00°
PF2	+1.000L	φ +0.00°
PF3	+1.000L	φ +0.00°

## DISPLAY OF DEVICE INFO



Long- touch Info to view informations about the energy meter (name, date, hour, firmware/technical informations, informations of locking, error informations).

Name	Instrument info	Date and hour
Finder <b>7M.38.8.400.0212</b> Energy Meter www.findernet.com	Info SN : X0000100 MID: 0.68 E65B A10B U 1 FUN: 0.68 5F35 1014 L 0 HW : A m.00005AB6 Run: 1d 5h 29' < Main menu	Info <b>24.08.2020</b> <b>12:49:57</b> Temperature 30.2°C
Icon info	Error info	
Info 🔒 Locked 🕒 Clock not set < Main menu	Info <b>Error 0</b> <b>Data CRC 00</b> <b>Code CRC 00</b> < Main menu	

Instrument info abbreviations:

SN: serial number

MID: Version and CRC of Part 2, U: upgrade counter

FUN: Version and CRC of Part 2, L: unlock counter

HW: Hardware version, m. : CRC of phase measuring modules (high, low)

Run: Operational time (days hours minutes)

## DISPLAY OF DEVICE SETTINGS

```

Main menu
ESC
Measurements
Info
Settings
Resets
Temperature 30.4°C
  
```

Long- touch Settings to enter the sub menu (table below).

### SETTINGS

```

ESC
General
Date & Time
Communication
LCD
Security
Energy
<= Main menu
  
```

## GENERAL

### GENERAL

```

ESC
Language
<= Settings
  
```

Long- touch General, the sub-menu is entered (ESC, Language). Long- touch ESC to return to the settings menu.

Long- touch Language to set language (the options are shown in pictures below).

Short-touch to chose the requested language, then long-touch ESC to confirm it.

```

Language
@English
O Francais
O Deutsch
O Español
O Slovenski
OK Select
  
```

```

Language
O Русский язык
O Dansk
O Italiano
O English US
O Hrvatski
OK Select
  
```

```

Language
O Polski
O Portuguese
O Hebrew
O Serbian
O Türkçe
OK Select
  
```

## DATE AND TIME

```

Date & Time
ESC
Date
Time
Automatic S/W time
< Settings
  
```

Long- touch Date and time, the sub-menu is entered (ESC, Date, Time. Automatic S/W time).

Long- touch ESC to return to the settings menu.

Long- touch Date to set the date and on Time to set the time. Long-touch Automatic S/W time to set automatically change between summer or winter time.

## PLEASE NOTE

The clock is for informational purposes only.

Date	Time	Automatic S/W time
Date DD.MM.YYYY <b>28.08.2020</b>	Time 9:47:47 <b>_9:47:47</b>	Automatic S/W time O No <b>@ Yes</b>
OK Select	OK Select	OK Select

## COMMUNICATION

Communication menu is available at M-bus and MODBus RS485 option (7M.38.8.400.0312 and 7M.38.8.400.0212) and can be used for setting communication parameters (communication addresses, bits per second, parity and stop bits).

### Communication

```

ESC
Device address
Bits per second
Parity
Stop bits
← Settings
  
```

Long-touch Communication, the sub-menu is entered (ESC, Device address, Bits per second, Parity, Stop bits). Long-touch ESC to return to the settings menu.

### Device address

```

_33
  
```

#### DEVICE ADDRESS

Long-touch Device address to set the address number. Non configured devices have the same factory Modbus address set to 33. Short-touch to move between the numbers.

Long-touch the selected number to save the value. Very long-touch to save the device address.

```

OK Select
  
```

### Bits per second

```

○ 2400 bit/s
○ 4800 bit/s
○ 9600 bit/s
○ 19200 bit/s
○ 38400 bit/s
  
```

```

OK Select
  
```

#### BITS PER SECOND

Long-touch Bits per second to set the value of specific communication.

### Bits per second

```

○ 9600 bit/s
○ 19200 bit/s
○ 38400 bit/s
○ 57600 bit/s
● 115200 bit/s
  
```

```

OK Select
  
```

### Parity

```

● None
○ Odd
○ Even
  
```

```

OK Select
  
```

#### PARITY

Set the party of communication (none, odd or even).

Long-touch to set the selection.

### Stop bits

```

○ 1
● 2
  
```

```

OK Select
  
```

#### STOP BITS

Set the stop bits of communication (1 or 2). Long press to set the selected value.

## LCD

```
LCD
ESC
Contrast
Back light
Back light time off
LCD scroll interval
← Settings
```

Long-touch LCD, the sub-menu is entered (ESC, Contrast, Backlight, Backlight time off, LCD scroll interval). Long-touch ESC to return to the settings menu

```
Contrast
0
OK Select
```

Long-touch Contrast to set the value of the contrast of the screen (from -10 to 10). Long-touch the selected value to save the settings.

```
Back light
10
OK Select
```

Long-touch Backlight to change the screen brightness (from 0 to 10). Long-touch the selected value to save the settings

```
Back light time off
_1 min.
OK Select
```

Long-touch Backlight time off to set the period of turn off the backlight of the screen (from 0 to 9 minutes or no).

Long-touch the selected value to save the settings.

```
LCD scroll interval
_5 sec.
OK Select
```

Long-touch the LCD scroll interval to set the value of the interval of scrolling measurements (from 5 seconds to 65 seconds).

Long-touch the selected value to save the settings.



## SECURITY

```
Security
ESC
Password level 1
Password level 2
Lock instrument
Unlock instrument
⇐ Settings
```

Long-touch Security, the sub-menu is entered (ESC, Password level 1, Password level 2, Lock instrument, unlock instrument). Long-touch ESC LCD returns to the settings menu. A password consists of four letters taken from the British alphabet from A to Z. When setting a password, only the letter being set is visible while the others are covered with •. Settings parameters are divided into single groups regarding security level: PL1 >password level 1, PL2 >password level 2 and BP >a backup password.

```
Password level 1
      A••••
OK Select
```

Long-touch Password level 1 to set the password (4 letters).  
Long-touch the selected letter to save the settings.  
Long-touch Password level 2 to set the password (4 letters).  
Long-touch the selected letter to save the settings.

```
Unlock instrument
      A••••
OK Select
```

Long-touch Lock instrument to lock the meter.  
Long-touch Unlock instrument to write the password for unlock (4 letters).  
Long-touch the selected letter to save the settings.

```
Energy
ESC
Active tariff
LED test
⇐ Settings
⊙ Tariff input
○ Tariff 1
○ Tariff 2
○ Tariff 3
○ Tariff 4
OK Select
```

Long-touch Energy, the sub-menu is entered (ESC, Active tariff, LED test).  
Long-touch ESC to return to the settings menu.

Long-touch Active tariff to set the tariff (Tariff input, tariff 1, 2, 3, 4, 5, 6).  
Long-touch the selection. Tariff management is possible for 16 NON-MID counters. As default management of 2 tariffs is possible using tariff input.  
In case all active MID registers from E1 to E4 are parameterized for cumulative energy (all tariffs) it is possible to set any single tariff as a set value.  
In this case, it is possible to switch 6 tariffs through a communication interface using the MODBUS register.

```
LED test
⊙ Normal
○ P fast
○ P fast cnt
○ P test
○ Q test
OK Select
```

Long-touch LED test to set specific test.  
Long-touch the selection.  
This function shall be used only for testing purposes during type testing and metrological verification of the meters.

```
LED test
○ P test
○ Q test
○ Q fast
○ Q fast cnt
○ 1 sec. Clock
OK Select
```

### TEST MODES:

Normal – 1000 imp/kWh, counter resolution 100 Wh/100 varh.

P fast (Test mode P Fast) – 100000 imp/kWh, counter resolution 1 Wh/1 varh.

P fast cnt (Test mode P Fast – counter only) – 1000 imp/kWh, counter resolution 1 Wh/1 varh.

P test (Test mode P) – 1000 imp/kWh, counter resolution 100 Wh/100 varh.

Q test (Test mode Q)– 1000 imp/kvarh, counter resolution 100 Wh/100 varh.

Q fast (Test mode Q fast) – 100000 imp/kvarh, counter resolution 1 Wh/1 varh.

Q fast cnt (Test mode Q fast - counter only) – 1000 imp/kvarh, counter resolution 1 Wh/1 varh.

Long-touch LED No. of pulses to set the number of pulses (). Long-touch the selection.

## DISPLAY OF DEVICE RESETS

```

Main menu
ESC
Measurements
Info
Settings
Resets
Temperature 30.5°C
  
```

Long-touch Reset, the sub-menu is entered (ESC, Energy counters, output).

```

RESETS
ESC
Energy counters
<= Main menu
  
```

## ENERGY COUNTERS

```

Resets
ESC
Energy counters
Reset alarm output
<= Main menu
  
```

```

Energy counters
ESC
All energy counters
Energy counter C1
Energy counter C2
Energy counter C3
<= Resets
  
```

Long-touch Energy counters to chose the counter to reset (ESC, All energy counters, from energy counter C1 to C16).  
Longtouch ESC to return to the Resets.

## INSTALLATION

```

Installation
ESC
Connection mode
  
```

Long-touch Installation to set the connection mode of the MID approved meter.

Long-touch ESC LCD returns to the Main menu.

```

<= Main menu
Installation
ESC
Connection mode
Not set
  
```

The connection mode can be set only once. Until the connection mode is not set, the warning screen appears every 5 seconds (Installation Not set).

Long-touch Connection mode setting menu is entered to select one of three options (see picture below):

- 3L+N, 3L, L+N – Vector (Evaluation of the sum of phases),
- 3L+N, L+N – Arithmetic (Evaluation of individual phases),
- 3L-2I – Vector (Evaluation of the sum of phases).

Evaluation of individual phases means that in case of opposite energy flow in different phases the energy is registered to both import and export registers taking into account each individual phase. It is applicable only in 4-wire connection.

```

Main menu
ESC
Measurements
Info
Settings
Resets
Temperature 30.5°C
  
```

Default value is the common three-phase 4-wire connection (3L+N) which enables also single-phase measurement in L3 (L+N) and 3-system 3-wire connection (3L) with import – export evaluation as the sum of phases.

Also this connection has to be confirmed to block further changes and after confirmation the message Installation not set is switched off.

In case 4-wire arithmetic mode with import-export evaluation for individual phases or 3-wire 2-system connection are chosen the password DCBA has to be entered to allow the modification. In 3L-2I connection the phase measurements are blocked on LCD while in 3L connection they are not automatically blocked.

It is recommended to remove phase voltage and power measurements at Displayed measurement setting as these are not relevant at 3-wire connection.

## ERROR DISPLAY ON LCD

Info

```

Error 0
Data CRC 00
Code CRC 00
Main menu
  
```

If error is detected Error display appears on LCD after each cycle for 5 seconds.

The first two bits are the summary description of CRC errors.

The decimal value of first 3 Bits (0 ...7) is displayed as Error.

The other bits are shown with 2 values:

- Data CRC – shows Parameter CRC details – decimal value (0...3f) of bits 8 to 13
- Code CRC – shows Firmware CRC details – decimal value (0 ...1f) of bits 3 to 7

## CALIBRATION AND SETTING PARAMETERS

Calibration parameters can only be changed in production.

They cannot be changed by upgrade or different processes.

Special factory software is used to calibrate the parameters for current, voltage, and phase angle.

If these parameters were tenaciously or accidentally changed, an error type 1 is detected and Error 1 is shown on the LCD.

Calibration parameters are checked every 64 seconds.

The parameters related to energy measurement can only be changed if the MID key is unlocked.

## TECHNICAL DATA

In following chapter all technical data regarding operation of a three-phase electrical energy meter is presented.

- ACCURACY
- MECHANICAL CHARACTERISTICS OF INPUT
- ELECTRICAL CHARACTERISTICS OF INPUT
- SAFETY AND AMBIENT CONDITIONS
- EU DIRECTIVES CONFORMITY
- DIMENSIONS

### ACCURACY

MEASURED VALUES	ACCURACY CLASS
ACTIVE ENERGY	class 1 EN 62053-21
	class B EN 50470-3
	±1.5% from $I_{min}$ to $I_{tr}$
	±1% from $I_{tr}$ to $I_{max}$
REACTIVE ENERGY	class 2 EN 62053-23
	±2.5% from $I_{min}$ to $I_{tr}$
	±2% from $I_{tr}$ to $I_{max}$
VOLTAGE	±1% of measured value
CURRENT	±1% of $I_{ref}$ from $I_{st}$ to $I_{ref}$
	±1% of measured value from $I_{ref}$ to $I_{max}$
ACTIVE POWER	±1% of nominal power ( $U_n * I_{ref}$ ) from $I_{st}$ to $I_{ref}$
	±1% of measured value from $I_{ref}$ to $I_{max}$
REACTIVE, APPARENT POWER	±2% of nominal power from $I_{st}$ to $I_{ref}$
	±2% of measured value from $I_{ref}$ to $I_{max}$
FREQUENCY	±0.5% of measured value

## MECHANICAL CHARACTERISTICS OF INPUT

Rail mounting according DIN EN 60715. In case of using the stranded wire, the ferrule must be attached before the mounting.

TERMINALS		MAX. CONDUCTOR CROSS-SECTIONS
MAIN INPUTS	Contacts capacitveacity:	1.5 mm <sup>2</sup> ... 25 (16) mm <sup>2</sup>
	Connection screws:	M5
	Max torque:	3.5 Nm (PH2)
	Length of removed isolation:	10 mm
OPTIONAL MODULES	Contacts capacitveacity:	0.5 mm <sup>2</sup> ... 1.5 mm <sup>2</sup>
	Connection screws:	M3
	Max torque:	0.6 Nm
	Length or removed isolation:	8 mm

## ELECTRICAL CHARACTERISTICS OF INPUT

TERMINALS		MAX. CONDUCTOR CROSS-SECTIONS
MEASURING INPUT	Type (connection):	three-phase (4u and 3u), single-phase (1b)
	Reference current $I_{ref}$	5 A
	Maximum current ( $I_{max}$ ):	80 A
	Minimum current ( $I_{min}$ ):	0.25 A
	Transitional current ( $I_{tr}$ ):	0.5 A
	Starting current:	20 mA
	Power consumption at $I_{ref}$ :	0.1 VA
	Nominal voltage ( $U_N$ ):	3x230 V/400 V (-20 %...+15 %)
	Power consumption per phase at $U_N$ :	< 8 VA
	Nominal frequency ( $f_n$ ):	50 Hz and 60 Hz
	Minimum measuring time:	10 s
PULSE OUTPUT S01	Pulse rate:	500 imp/kWh
	Pulse duration:	32 ms $\pm$ 2 ms
	Rated voltage DC (max):	27 V
	Switched current (max):	27 mA
	Standard:	EN 62053-31 (A&B)
PULSE OUTPUT S02	Type:	Programmable
	Rated voltage DC (max):	27 V
	Switched current (max):	27 mA
M-BUS SERIAL COMMUNICATION (OPTION)	Type:	M-BUS
	Speed:	300 bit/s to 9600 bit/s (default 2400 bit/s)
	Protocol:	M-BUS
	Primary address:	0 – (default)
RS485 SERIAL COMMUNICATION (OPTION)	Type:	RS485
	Speed:	1200 bit/s to 115200 bit/s (default 19200 bit/s)
	Frame:	8, N, 2
	Protocol:	MODBUS RTU
	Address:	33 – (default)
OPTICAL IR COMMUNICATION	Type:	IR
	Connection:	via USB adapter
	Speed:	19200 bit/s
	Frame:	8, N, 2
	Protocol:	MODBUS RTU
	Address:	33
	Remark:	All settings are fixed
NFC	Protocol:	ISO/IEC 14443 Part 2 and 3 compliant
	Frequency range:	13.56 Mhz
	Baudrate:	106 kbps
	Operating distance:	up to 15 mm from LCD (distance depends on used reader)
TARIFF INPUT (OPTION)	Rated voltage:	230 V (+15 % -20 %)
	Input resistance:	450 kOhm
	Rated voltage:	230 V (+15 % -20 %)
	Maximum load current:	50 mA

## SAFETY AND AMBIENT CONDITIONS

According to standards for indoor active energy meters.

Temperature and climatic condition according to EN 62052-11.

<b>DUST/WATER PROTECTION:</b>	IP50 (For IP51 it should be installed in appropriate cabinet.)
<b>OPERATING TEMPERATURE:</b>	-25 °C - +70 °C (non-condensing humidity)
<b>STORAGE TEMPERATURE:</b>	-40 °C - + 85°C
<b>ENCLOSURE:</b>	self extinguish, complying UL94-V
<b>INDOOR METER:</b>	Yes
<b>DEGREE OF POLLUTION:</b>	2
<b>PROTECTION CLASS:</b>	II
<b>INSTALLATION CATEGORY</b>	300 Vrms cat.III
<b>STANDARD:</b>	IEC 62052-31
<b>MECHANICAL ENVIRONMENT:</b>	M1
<b>ELECTROMAGNETIC ENVIRONMENT:</b>	E2
<b>HUMIDITY:</b>	non condensing
<b>MAX WEIGHT (WITH PACKAGING):</b>	225 g (258.5 g)
<b>INSTALLATION:</b>	DIN Rail 35 mm
<b>DIMENSIONS (W X H X D):</b>	52.5 mm x 91.7 mm x 68.2 mm
<b>PACKAGE DIMENSIONS (W X H X D):</b>	74 mm x 106 mm x 80 mm
<b>COLOUR:</b>	RAL 7035

## EU DIRECTIVES CONFORMITY

### MID CERTIFIED METERS

MID APPROVAL APPLIES TO NON-RESETTABLE ACTIVE ENERGY COUNTERS.

EU DIRECTIVE ON MEASURING INSTRUMENTS 2014/32/EU

EU DIRECTIVE ON EMC 2014/30/EU

EU DIRECTIVE ON LOW VOLTAGE 2014/35/EU

EU DIRECTIVE WEEE 2002/96/EC

EU RED DIRECTIVE 2014/53/EU

## DIMENSIONS

### DIMENSIONAL DRAWING

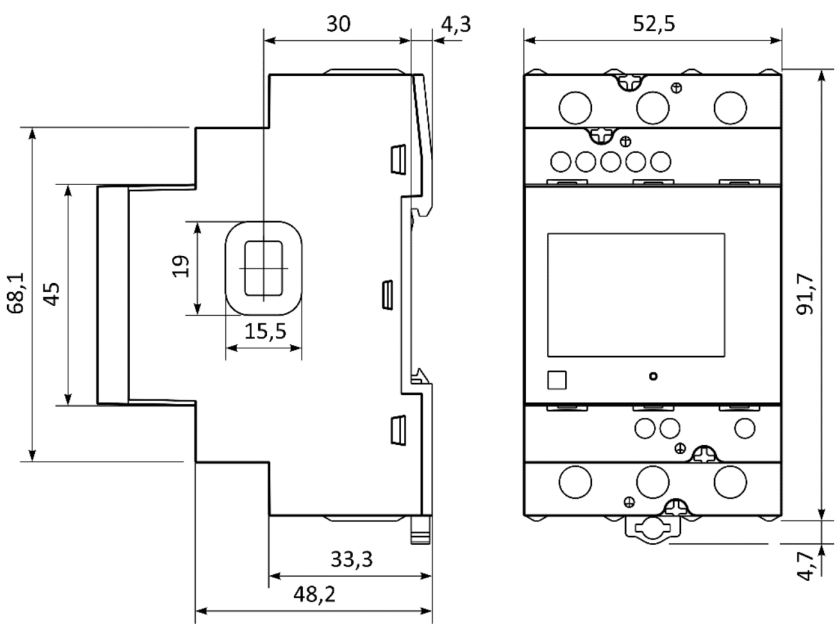
CONSTRUCTION	APPEARANCE
DIMENSIONS	<p>All dimensions are in mm</p>  <p>The drawing shows two views of the meter. The side view on the left indicates a total height of 68,1 mm, a main body height of 45 mm, a top section height of 19 mm, and a bottom section height of 33,3 mm. The total width is 48,2 mm, with a top section width of 30 mm and a bottom section width of 33,3 mm. A small detail shows a width of 15,5 mm. The front view on the right shows a total width of 52,5 mm and a total height of 91,7 mm, with a bottom section height of 4,7 mm.</p>

## ABBREVIATION/GLOSSARY

Abbreviations are explained within the text where they appear the first time.  
Most common abbreviations and expressions are explained in the following table:

TERM	EXPLANATION
MODBUS	Industrial protocol for data transmission
FI-MIS	Setting Software for FINDER S.p.A instruments
ETHERNET	IEEE 802.3 data layer protocol
AC	Alternating quantity
PI	Pulse input module
IR	Infrared (optical) communication
RMS	Root Mean Square
TRMS	True Root Mean Square
PO	Pulse output
PA	Power angle (between current and voltage)
PF:	Power factor
THD	Total harmonic distortion
RTC:	Real-time clock
NFC	Near Field Communication
NC	Not connected
SC:	Shield
SW	Software
MID	Measuring Instruments Directive

**Table 10:** List of common abbreviations and expressions



# APPENDICES

## APPENDIX A: MODBUS - COMMUNICATION PROTOCOL

Modbus protocol enables operation of device on Modbus networks. For 7M.38.8.400.XXXX\ with serial communication the Modbus protocol enables multi drop communication via RS485 communication. Modbus protocol is a widely supported open interconnect originally designed by Modicon.

The memory reference for input and holding registers is 30000 and 40000 respectively.

### PLEASE NOTE

The Modbus table is subject to change without notice.

For the latest and complete Modbus table please visit FINDER S.p.A web page.

Communication operates on a master-slave basis where only one device (the master) can initiate transactions called 'Requests'. The other devices (slaves) respond by supplying the requested data to the master. This is called the 'Request - Response Cycle'. The master could send the MODBUS request to the slaves in two modes:

- **Unicast mode**, where the master sends the request to an individual slave. It returns a replay to the master after the request is received and processed. A MODBUS transaction consists of two messages. Each slave should have a unique address.
- **Broadcast mode**, where the master sends a request to all slaves and an answer is never followed. All devices should accept the broadcast request function. The Modbus address 0 is reserved to identify the broadcast request.

#### MASTER TO SLAVE REQUEST

Device address	Function Code	nx8 bit data bytes	Error check
----------------	---------------	--------------------	-------------

#### SLAVE TO MASTER RESPONSE

Device address	Function Code	nx8 bit data bytes	Error check
----------------	---------------	--------------------	-------------

#### REQUEST

This Master to Slave transaction takes the form:

- **Device address**: master addressing a slave (Address 0 is used for the broadcast address, which all slave devices recognize)
- **Function code** e.g. 03 asks the slave to read its registers and respond with their contents
- **Data bytes**: tells the slave which register to start at and how many registers to read

#### RESPONSE

This Slave to Master transaction takes the form:

- **Device address**: to let the master know which slave is responding
- **Function code**: this is an echo of the request function code
- **Data bytes**: contains the data collected from the slave

## REQUEST FRAME

		Starting Register	Register Count	CRC
Slave Address	Function Code	HI LO	HI LO	LO HI
21	04	00 6B	00 02	

## RESPONSE FRAME

			Register Data	CRC
Slave Address	Function Code	Byte Count	HI LO HI LO	LO HI
21	04	04	FE 00 59 96	

Address number of slave: 21

Function code: 04 → 30000

Starting register HI...LO: 00...6B<sub>(16)</sub> → 107<sub>(10)</sub> + 30000<sub>(10)</sub> = 30107<sub>(10)</sub>

(Meaning that actual measurement is U1. For further informations see REGISTER TABLE FOR THE ACTUAL MEASUREMENTS.)

Register count HI...LO: 00...02<sub>(16)</sub> → 2<sub>(10)</sub> (Two registers: 30107 and 30108)

Data type: T5 (Unsigned Measurement (32 bit) – see table of DATA types decoding)

Register data: FE 00 59 74<sub>(16)</sub> → 22934 \* 10<sup>-2</sup> V = 229,34 V

## REGISTER TABLE FOR THE ACTUAL MEASUREMENTS

The tables below represent the complete set of MODBUS register map. Register refresh frequency for actual measurement from register 30105 to register 30190 is one second. Register refresh frequency for energy counters (from 30406 to 30441) is 40 ms.

The registers from 30426 to 30441 (1000 x Energy Counter from 30406 to 30413 and from 30418 to 30425) represent the same energy counters at 1000-times higher resolution.

This registers can be read to calculate the energy difference in the time interval more accurate.

Address		Contents	Data	Ind	Values / Dependencies
		Input Registers			
		READ ONLY INFO			
30000		Memory Reference			
		READ ONLY INFO			
30001	30008	Model Number	T_Str16		
30009	30012	Serial Number	T_Str8		
30013		Software Reference	T1		Software version
30014		Hardware Reference	T_Str2		Hardware version
30015		Calibration voltage	T16		V/100
30017		Calibration current	T16		A/100
30019		Accuracy class	T17		100=1,00
30020		MiNet Flag	T1	0	
30024		COM1: Communication Type	T1	0	No Communication
				2	RS485
				13	M-bus
				15	WiFi
30028		Memory type	T1	0	No memory
				3	8 MB Flash
				4	16 MB Flash
30029		I/O 1	T1	0	No I/O
				5	Tariff Input
				10	Digital input
				12	Pulse Output (SO)
30030		I/O 2	T1		See I/O 1
30031		I/O 3	T1		See I/O 1
30032		I/O 4	T1		See I/O 1
30044		Status register	T1	Bit-0	Locked
				Bit-1	Wrong connection
				Bit-2	Low battery
				Bit-3	Low supply
				Bit-4	Clock not set
30055	30057	Ethernet MAC Address	T_Hex6		
30058		Ethernet Software Reference	T1		Ethernet Software version
30059	30060	Ethernet: IP Address	T_Hex4		Actual Ethernet IP Address
30061		phase module 1 Software reference	T17		100=1,0
30062		phase module 2 Software reference	T17		100=1,0
30063		phase module 3 Software reference	T17		100=1,0
30064		phase module 1 CheckSum	T1		
30065		phase module 2 CheckSum	T1		
30066		phase module 3 CheckSum	T1		
30067		phase m. 1 Calibration Data CheckSum	T1		
30068		phase m. 2 Calibration Data CheckSum	T1		
30069		phase m. 3 Calibration Data CheckSum	T1		
30070		Measurement module Software ref.	T17		100=1,0
30071		Measurement module CheckSum	T1		
30072		Meas. m. Calibration Data CheckSum	T1		

Address		Contents	Data	Ind	Values / Dependencies
		Input Registers			
30073		MID Setting Data CheckSum	T1		
30074		Setting Data CheckSum	T1		
30075		Software Checksum	T1		
30076		MID lock status	T1	0	unlocked
				1	locked
30077	30078	Calibration Time Stamp	T_unix		
30079		MID unlock counter	T1		
30080		FW upgrade counter	T1		
30081		Software Checksum HI	T1		
30082		Measurement module CheckSum HI	T1		
30083		phase module 1 CheckSum HI	T1		
30084		phase module 2 CheckSum HI	T1		
30085		phase module 3 CheckSum HI	T1		
30097		Software options	T1		
30098		Active Communication Port	T1	1	COM1
30099		Modbus Max. Register Read at Once	T1		
39000		Device group	T1	5	7M

Address		Contents	Data	Ind	Values / Dependencies
		Input Registers			
<b>ACTUAL MEASUREMENTS</b>					
30101		Phase valid measurement	T1	Bit 0	Invalid measurement phase 1
				Bit 1	Invalid measurement phase 2
				Bit 2	Invalid measurement phase 3
30102		reserved			
30103	30104	Run time	T3		seconds
30105	30106	Frequency	T5		
30107	30108	U1	T5		
30109	30110	U2	T5		
30111	30112	U3	T5		
30113	30114	Uavg (phase to neutral)	T5		
30115		j12 (angle between U1 and U2)	T17		
30116		j23 (angle between U2 and U3)	T17		
30117		j31 (angle between U3 and U1)	T17		
30118	30119	U12	T5		
30120	30121	U23	T5		
30122	30123	U31	T5		
30124	30125	Uavg (phase to phase)	T5		
30126	30127	I1	T5		
30128	30129	I2	T5		
30130	30131	I3	T5		
30132	30133	INc	T5		
30134	30135	Inm - reserved	T5		
30136	30137	Iavg	T5		
30138	30139	S I	T5		
30140	30141	Active Power Total (Pt)	T6		
30142	30143	Active Power Phase L1 (P1)	T6		
30144	30145	Active Power Phase L2 (P2)	T6		
30146	30147	Active Power Phase L3 (P3)	T6		
30148	30149	Reactive Power Total (Qt)	T6		
30150	30151	Reactive Power Phase L1 (Q1)	T6		
30152	30153	Reactive Power Phase L2 (Q2)	T6		
30154	30155	Reactive Power Phase L3 (Q3)	T6		
30156	30157	Apparent Power Total (St)	T5		
30158	30159	Apparent Power Phase L1 (S1)	T5	30158	30159
30160	30161	Apparent Power Phase L2 (S2)	T5	30160	30161
30162	30163	Apparent Power Phase L3 (S3)	T5	30162	30163
30164	30165	Power Factor Total (PFt)	T7	30164	30165
30166	30167	Power Factor Phase 1 (PF1)	T7	30166	30167
30168	30169	Power Factor Phase 2 (PF2)	T7	30168	30169
30170	30171	Power Factor Phase 3 (PF3)	T7	30170	30171

30174		angle between U2 and I2	T17		
30175		angle between U3 and I3	T17		
30181		Internal Temperature	T17		
		<b>THD HARMONIC DATA</b>			
30182		U1 THD%	T16		
30183		U2 THD%	T16		
30184		U3 THD%	T16		
30188		I1 THD%	T16		
30189		I2 THD%	T16		
30190		I3 THD%	T16		
		<b>I/O STATUS</b>			
30191		Alarm Status Flags(G1, G2	T1	Bit 0..4 Bit 8..12	Group 1 Limit 1 .. 4 Group 2 Limit 1 .. 4
30192		Alarm Status Flags(G3, G4	T1	Bit 0..4	Group 3 Limit 1 .. 4
30193		I/O 1 Value	T17		
30194		I/O 2 Value	T17		
30195		I/O 3 Value	T17		
30196		I/O 4 Value	T17		
30197		External relay status	T1	0	Off
				1	On
				250	Comm. Error
				255	Not connected
30198		Reserved for Load control output status	T1	0	Off
				1	On
30199		Reserved for Digital input status	T1	0	Off
				1	On
30200		Alarm Status Flags(GE	T1	Bit 0..4	Group E Limit 1 .. 4
30201		Logic functions values	T1	Bit 0	Logic function 1
				Bit 1	Logic function 2
				Bit 2	Logic function 3
30202	30395	Reserved			
30396	30399	Actual time	T_Time		

Address		Contents	Data	Ind	Values / Dependencies
		Input Registers			
<b>ENERGY</b>					
30400		CheckSum Status	T1	0	No Error (OK)
				Bit 0	Error Parameter CRC
				Bit 1	Error Firmware CRC
				Bit 2	Error MID-lock
				Bit 3	Error phase module 1 CheckSum
				Bit 4	Error phase module 2 CheckSum
				Bit 5	Error phase module 3 CheckSum
				Bit 6	Error Measurement module CheckSum
				Bit 7	Error Software Checksum
				Bit 8	Error Calibration Data CheckSum
				Bit 9	Error MID Setting Data CheckSum
				Bit 10	Error Setting Data CheckSum
				Bit 11	Error phase m. 1 Cal. Data CheckSum
				Bit 12	Error phase m. 2 Cal. Data CheckSum
				Bit 13	Error phase m. 3 Cal. Data CheckSum
			Bit 15	Instalation not set	
30401		Energy Counter n1 Exponent	T2		
30402		Energy Counter n2 Exponent	T2		
30403		Energy Counter n3 Exponent	T2		
30404		Energy Counter n4 Exponent	T2		
30405		Current Active Tariff	T1		
30406	30407	Energy Counter n1	T3		
30408	30409	Energy Counter n2	T3		
30410	30411	Energy Counter n3	T3		
30412	30413	Energy Counter n4	T3		
30414	30415	Energy Counter 1	T3		
30416	30417	Energy Counter 2	T3		
30418	30419	Energy Counter 3	T3		
30420	30421	Energy Counter 4	T3		
30422	30423	Energy Counter 5	T3		
30424	30425	Energy Counter 6	T3		
30426	30427	Energy Counter 7	T3		
30428	30429	Energy Counter 8	T3		
30430	30431	Energy Counter 9	T3		
30432	30433	Energy Counter 10	T3		
30434	30435	Energy Counter 11	T3		
30436	30437	Energy Counter 12	T3		
30438	30439	Energy Counter 13	T3		
30440	30441	Energy Counter 14	T3		
30442	30443	Energy Counter 15	T3		
30444	30445	Energy Counter 16	T3		

Address		Contents	Data	Ind	Values
		ENERGY			
30446		Energy Counter 1 Exponent	T2		
30447		Energy Counter 2 Exponent	T2		
30448		Energy Counter 3 Exponent	T2		
30449		Energy Counter 4 Exponent	T2		
30450		Energy Counter 5 Exponent	T2		
30451		Energy Counter 6 Exponent	T2		
30452		Energy Counter 7 Exponent	T2		
30453		Energy Counter 8 Exponent	T2		
30454		Energy Counter 9 Exponent	T2		
30455		Energy Counter 10 Exponent	T2		
30456		Energy Counter 11 Exponent	T2		
30457		Energy Counter 12 Exponent	T2		
30458		Energy Counter 13 Exponent	T2		
30459		Energy Counter 14 Exponent	T2		
30460		Energy Counter 15 Exponent	T2		
30461		Energy Counter 16 Exponent	T2		
30462	30463	1000 x Energy Counter n1	T3		
30464	30465	1000 x Energy Counter n2	T3		
30466	30467	1000 x Energy Counter n3	T3		
30468	30469	1000 x Energy Counter n4	T3		
30470	30471	1000 x Energy Counter 1	T3		
30472	30473	1000 x Energy Counter 2	T3		
30474	30475	1000 x Energy Counter 3	T3		
30476	30477	1000 x Energy Counter 4	T3		
30478	30479	1000 x Energy Counter 5	T3		
30480	30481	1000 x Energy Counter 6	T3		
30482	30483	1000 x Energy Counter 7	T3		
30484	30485	1000 x Energy Counter 8	T3		
30486	30487	1000 x Energy Counter 9	T3		
30488	30489	1000 x Energy Counter 10	T3		
30490	30491	1000 x Energy Counter 11	T3		
30492	30493	1000 x Energy Counter 12	T3		
30494	30495	1000 x Energy Counter 13	T3		
30496	30497	1000 x Energy Counter 14	T3		
30498	30499	1000 x Energy Counter 15	T3		
30500	30501	1000 x Energy Counter 16	T3		



Address		Contents	Data	Ind	Values
		ENERGY			
32480	32481	Run time	T_float		seconds
32482	32483	Reserved for Frequency (fast response)	T_float		
32484	32485	Uavg (phase to neutral)	T_float		
32486	32487	Uavg (phase to phase)	T_float		
32488	32489	S I	T_float		
32490	32491	Active Power Total (Pt)	T_float		
32492	32493	Reactive Power Total (Qt)	T_float		
32494	32495	Apparent Power Total (St)	T_float		
32496	32497	Power Factor Total (PFt)	T_float		
32498	32499	Frequency	T_float		
32500	32501	U1	T_float		
32502	32503	U2	T_float		
32504	32505	U3	T_float		
32506	32507	Uavg (phase to neutral)	T_float		
32508	32509	U12	T_float		
32510	32511	U23	T_float		
32512	32513	U31	T_float		
32514	32515	Uavg (phase to phase)	T_float		
32516	32517	I1	T_float		
32518	32519	I2	T_float		
32520	32521	I3	T_float		
32522	32523	S I	T_float		
32524	32525	I neutral (calculated)	T_float		
32526	32527	I neutral (measured)	T_float		
32528	32529	Iavg	T_float		
32530	32531	Active Power Phase L1 (P1)	T_float		
32532	32533	Active Power Phase L2 (P2)	T_float		
32534	32535	Active Power Phase L3 (P3)	T_float		
32536	32537	Active Power Total (Pt)	T_float		
32538	32539	Reactive Power Phase L1 (Q1)	T_float		
32540	32541	Reactive Power Phase L2 (Q2)	T_float		
32542	32543	Reactive Power Phase L3 (Q3)	T_float		
32544	32545	Reactive Power Total (Qt)	T_float		
32546	32547	Apparent Power Phase L1 (S1)	T_float		
32548	32549	Apparent Power Phase L2 (S2)	T_float		
32550	32551	Apparent Power Phase L3 (S3)	T_float		
32552	32553	Apparent Power Total (St)	T_float		
32554	32555	Power Factor Phase 1 (PF1)	T_float		
32556	32557	Power Factor Phase 2 (PF2)	T_float		
32558	32559	Power Factor Phase 3 (PF3)	T_float		
32560	32561	Power Factor Total (PFt)	T_float		
32562	32563	CAP/IND P. F. Phase 1 (PF1)	T_float		
32564	32565	CAP/IND P. F. Phase 2 (PF2)	T_float		
32566	32567	CAP/IND P. F. Phase 3 (PF3)	T_float		

32568	32569	CAP/IND P. F. Total (PFt)	T_float		
32570	32571	j1 (angle between U1 and I1)	T_float		
32572	32573	j2 (angle between U2 and I2)	T_float		
32574	32575	j3 (angle between U3 and I3)	T_float		
32576	32577	Power Angle Total (atan2(Pt,Qt))	T_float		
32578	32579	j12 (angle between U1 and U2)	T_float		
32580	32581	j23 (angle between U2 and U3)	T_float		
32582	32583	j31 (angle between U3 and U1)	T_float		
32584	32585	Frequency	T_float		
32586	32587	Reserved			
32588	32589	I1 THD%	T_float		
32590	32591	I2 THD%	T_float		
32592	32593	I3 THD%	T_float		
32638	32639	Energy Counter n1	T_float		
32640	32641	Energy Counter n2	T_float		
32642	32643	Energy Counter n3	T_float		
32644	32645	Energy Counter n4	T_float		
32658	32659	Internal Temperature	T_float		
		<b>ENERGY</b>			
32750	32751	Aktiv Tariff	T_float		
32752	32753	Energy Counter n1	T_float		
32754	32755	Energy Counter n2	T_float		
32756	32757	Energy Counter n3	T_float		
32758	32759	Energy Counter n4	T_float		
32760	32761	Energy Counter 1	T_float		
32762	32763	Energy Counter 2	T_float		
32764	32765	Energy Counter 3	T_float		
32766	32767	Energy Counter 4	T_float		
32768	32769	Energy Counter 5	T_float		
32770	32771	Energy Counter 6	T_float		
32772	32773	Energy Counter 7	T_float		
32774	32775	Energy Counter 8	T_float		
32776	32777	Energy Counter 9	T_float		
32778	32779	Energy Counter 10	T_float		
32780	32781	Energy Counter 11	T_float		
32782	32783	Energy Counter 12	T_float		
32784	32785	Energy Counter 13	T_float		
32786	32787	Energy Counter 14	T_float		
32788	32789	Energy Counter 15	T_float		
32790	32791	Energy Counter 16	T_float		
		NOMINAL VALUES			
32985	32986	nominal phase voltage	T_float		Unom
32987	32988	nominal phase current	T_float		Inom
32989	32990	nominal phase power	T_float		Pnom
32991	32992	nominal total power	T_float		Ptot
32993	32994	nominal total current	T_float		Itot
32995	32996	nominal frequency	T_float		Fnom
34999	35000	Run time	T3		seconds

## INTERVAL MEASUREMENTS

Interval measurements are intended for data collection and synchronization of the time for data reading, through the communication. The time interval of data reading is programmable, by default is one minute.

The minimum and maximum measurements could be read within a given time interval.

Address		Contents	Data	Ind	Values / Dependencies
		Input Registers			
		AVERAGE MEASUREMENTS			
35500		The last Average interval duration	T1		Seconds/10
35501		Time since the last average measurements	T1		Seconds/10
35502		Average measurements counter	T1		
35503	35504	Timestamp (Run time)	T_unix		'= 0 after reset
35505	35506	Frequency	T5		
35507	35508	U1	T5		
35509	35510	U2	T5		
35511	35512	U3	T5		
35513	35514	Uavg (phase to neutral)	T5		
35515		j12 (angle between U1 and U2)	T17		
35516		j23 (angle between U2 and U3)	T17		
35517		j31 (angle between U3 and U1)	T17		
35518	35519	U12	T5		
35520	35521	U23	T5		
35522	35523	U31	T5		
35524	35525	Uavg (phase to phase)	T5		
35526	35527	I1	T5		
35528	35529	I2	T5		
35530	35531	I3	T5	35530	35531
35536	35537	Iavg	T5		
35538	35539	S I	T5		
35540	35541	Active Power Total (Pt)	T6		
35542	35543	Active Power Phase L1 (P1)	T6		
35544	35545	Active Power Phase L2 (P2)	T6		
35546	35547	Active Power Phase L3 (P3)	T6		
35548	35549	Reactive Power Total (Qt)	T6		
35550	35551	Reactive Power Phase L1 (Q1)	T6		
35552	35553	Reactive Power Phase L2 (Q2)	T6		
35554	35555	Reactive Power Phase L3 (Q3)	T6		
35556	35557	Apparent Power Total (St)	T5		
35558	35559	Apparent Power Phase L1 (S1)	T5		
35560	35561	Apparent Power Phase L2 (S2)	T5		
35562	35563	Apparent Power Phase L3 (S3)	T5		
35564	35565	Power Factor Total (PFt)	T7		
35566	35567	Power Factor Phase 1 (PF1)	T7		
35568	35569	Power Factor Phase 2 (PF2)	T7		
35570	35571	Power Factor Phase 3 (PF3)	T7		
35572		Power Angle Total (atan2(Pt,Qt))	T17		
35573		j1 (angle between U1 and I1)	T17		
35574		j2 (angle between U2 and I2)	T17		
35575		j3 (angle between U3 and I3)	T17		

Address		Contents	Data	Ind	Values / Dependencies
		<b>Input Registers</b>			
		<b>AVERAGE MEASUREMENTS</b>			
		<b>THD HARMONIC DATA</b>			
35582		U1 THD%	T16		
35583		U2 THD%	T16		
35584		U3 THD%	T16		
35588		I1 THD%	T16		
35589		I2 THD%	T16		
35590		I3 THD%	T16		
		<b>MAXIMUM MEASUREMENTS</b>			
35605	35606	Frequency	T5		
35607	35608	U1	T5		
35609	35610	U2	T5		
35611	35612	U3	T5		
35613	35614	Uavg (phase to neutral)	T5		
35615		j12 (angle between U1 and U2)	T17		
35616		j23 (angle between U2 and U3)	T17		
35617		j31 (angle between U3 and U1)	T17		
35618	35619	U12	T5		
35620	35621	U23	T5		
35622	35623	U31	T5		
35624	35625	Uavg (phase to phase)	T5		
35626	35627	I1	T5		
35628	35629	I2	T5		
35630	35631	I3	T5		
35632	35633	Reserved: Inc	T5		
35634	35635	Reserved: Inm	T5		
35636	35637	Iavg	T5		
35638	35639	S I	T5		
35640	35641	Active Power Total (Pt)	T6		
35642	35643	Active Power Phase L1 (P1)	T6		
35644	35645	Active Power Phase L2 (P2)	T6		
35646	35647	Active Power Phase L3 (P3)	T6		
35648	35649	Reactive Power Total (Qt)	T6		
35650	35651	Reactive Power Phase L1 (Q1)	T6		
35652	35653	Reactive Power Phase L2 (Q2)	T6		
35654	35655	Reactive Power Phase L3 (Q3)	T6		
35656	35657	Apparent Power Total (St)	T5		
35658	35659	Apparent Power Phase L1 (S1)	T5		
35660	35661	Apparent Power Phase L2 (S2)	T5		
35662	35663	Apparent Power Phase L3 (S3)	T5		
35664	35665	Power Factor Total (PFt)	T7		
35666	35667	Power Factor Phase 1 (PF1)	T7		
35668	35669	Power Factor Phase 2 (PF2)	T7		
35670	35671	Power Factor Phase 3 (PF3)	T7		
35672		Power Angle Total (atan2(Pt,Qt))	T17		
35673		j1 (angle between U1 and I1)	T17		
35674		j2 (angle between U2 and I2)	T17		

Address		Contents	Data	Ind	Values / Dependencies
		<b>Input Registers</b>			
		<b>AVERAGE MEASUREMENTS</b>			
35675		j3 (angle between U3 and I3)	T17		
35681		Internal Temperature	T17		
		<b>THD HARMONIC DATA</b>			
35682		U1 THD%	T16		
35683		U2 THD%	T16		
35684		U3 THD%	T16		
35685		U12 THD%	T16		
35686		U23 THD%	T16		
35687		U31 THD%	T16		
35688		I1 THD%	T16		
35689		I2 THD%	T16		
35690		I3 THD%	T16		
		<b>MINIMUM MEASUREMENTS</b>			
35700	35704	Reserved			
35705	35706	Frequency	T5		
35707	35708	U1	T5		
35709	35710	U2	T5		
35711	35712	U3	T5		
35713	35714	Uavg (phase to neutral)	T5		
35715		j12 (angle between U1 and U2)	T17		
35716		j23 (angle between U2 and U3)	T17		
35717		j31 (angle between U3 and U1)	T17		
35718	35719	U12	T5		
35720	35721	U23	T5		
35722	35723	U31	T5		
35724	35725	Uavg (phase to phase)	T5		
35726	35727	I1	T5		
35728	35729	I2	T5		
35730	35731	I3	T5		
35736	35737	Iavg	T5		
35738	35739	S I	T5		
35740	35741	Active Power Total (Pt)	T6		
35742	35743	Active Power Phase L1 (P1)	T6		
35744	35745	Active Power Phase L2 (P2)	T6		
35746	35747	Active Power Phase L3 (P3)	T6		
35748	35749	Reactive Power Total (Qt)	T6		
35750	35751	Reactive Power Phase L1 (Q1)	T6		
35752	35753	Reactive Power Phase L2 (Q2)	T6		
35754	35755	Reactive Power Phase L3 (Q3)	T6		
35756	35757	Apparent Power Total (St)	T5		
35758	35759	Apparent Power Phase L1 (S1)	T5		
35760	35761	Apparent Power Phase L2 (S2)	T5		
35762	35763	Apparent Power Phase L3 (S3)	T5		
35764	35765	Power Factor Total (PFt)	T7		
35766	35767	Power Factor Phase 1 (PF1)	T7		
35768	35769	Power Factor Phase 2 (PF2)	T7		
35770	35771	Power Factor Phase 3 (PF3)	T7		

Address		Contents	Data	Ind	Values / Dependencies
		<b>Input Registers</b>			
		<b>AVERAGE MEASUREMENTS</b>			
35772		Power Angle Total (atan2(Pt,Qt))	T17		
35773		j1 (angle between U1 and I1)	T17		
35774		j2 (angle between U2 and I2)	T17		
35775		j3 (angle between U3 and I3)	T17		
35781		Internal Temperature	T17		
		<b>THD HARMONIC DATA</b>			
35782		U1 THD%	T16		
35783		U2 THD%	T16		
35784		U3 THD%	T16		
35785		U12 THD%	T16		
35786		U23 THD%	T16		
35787		U31 THD%	T16		
35788		I1 THD%	T16		
35789		I2 THD%	T16		
35790		I3 THD%	T16		

**RAM logger**

36000		Measurement parameter	T1		See OutTypes
36001		Time interval	T1		minuteas
36002		Number of valid results	T1		
36003		Time stamp of last result	T2		minutes since midnight (<0 if no time)
36004	36131	Logger table (newest to oldest)	T17		Normalised values

**SETTINGS**

		<b>SYSTEM COMMANDS</b>						
40001	40002	User Password (L1, L2)	T_Str4	A...Z	Password to attempt user access level upgrade			0
40003	40005	Factory Password (FAC)	T_Str6	A...Z	Password to attempt factory access level upgrade			0
40006	40007	Level 1 - User password	T_Str4	A...Z				1
40008	40009	Level 2 - User password	T_Str4	A...Z				2
40010		Active Acces Level	T1	0	Full protection	0	0	0
				1	Access up to level 1 user password			
				2	Access up to level 2 user password			
				3	Access up to level 2 (backup pass.)			
				4	Factory access level			
40011		Manual password activation	T1	1	Lock instrument			0
40012		Operator Command Register	T1	1	Save Settings	1	5	1
				2	Abort Settings			
				3	Restart Instrument			
40014		Reset command register 2	T1	Bit-0	Reset alarm ouptut relay 1			1
				Bit-1	Reset alarm ouptut relay 2			
				Bit-8	Reset alarm ouptut IR			
40015		IR external relay command action		0	Off	0	1	0

				1	On			
40030		Select Active Tariff	T1			1	6	1
40031		Reset energy command register 1	T1	Bit-0..7	Reset counter 1 .. 8	0	65535	1
				Bit-8...15	Reset counter 9 .. 16			
40032		Reset energy command register 2	T1	Bit-i	Reset counter i+17	0	65535	1
<b>INSTALATION SETTINGS</b>								
40051	40052	Instalation Password	T_Str4	A...Z	Password to attempt instalation access level			0
40053		Connection and Total Energy Calculation	T1	0	Not set	0	3	0
				1	4u, 1b, 3u(3L) – Vector			
				2	4u, 1b - Aritmetic			
				3	3u(3L-2l) - Vector			
<b>GENERAL SETTINGS</b>								
40101	40120	Description	T_Str40					2
40121	40140	Location	T_Str40					2
40143		Conection Mode	T1	0	No mode	1	5	2
				1	1b - Single Phase			
				2	3b - 3 phase 3 wire balanced			
				3	4b - 3 phase 4 wire balanced			
				4	3u - 3 phase 3 wire unbalanced			
				5	4u - 3 phase 4 wire unbalanced			
40144		CT Secondary	T4		mA			2
40145		CT Primary	T4		A/10			2
40146		VT Secondary	T4		mV			2
40147		VT Primary	T4		V/10			2
40148		Current input range (%)	T16		10000 for 100%	5,00	260,00	2
40149		Voltage input range (%)	T16		10000 for 100%	2,50	100,00	2
40150		Frequency nominal value	T1		Hz	50	50	2
40151		CT connection	T1	Bit-0	Disable display "Wrong connection"			2
				Bit-1	Reverse Energy flow direction			
				Bit-2	Reverse CT connection			
40161	40162	Time	T9					1
40163	40164	Date	T10					1
40166		Automatic change S/W time	T1	0	No	0	1	1
40170		LCD configurations	T1	Bit 0	Counter description mode (*0=OBIS code; 1=letters)	0	1	2
40171		LCD Contrast	T2			-10	10	2
40172		LCD Back Light Intesnity	T1		0=No Backlight	0	10	2
40173		LCD Back Light Time Off	T1		Minutes (0= Always on)	0	60	2
40174		LCD scroll interval	T1		Seconds	5	60	2
40175		LCD Custom screen 1 - Line 1	T1		See OutTypes	0	100	2
40176		LCD Custom screen 1 - Line 2	T1		See OutTypes	0	100	2
40177		LCD Custom screen 1 - Line 3	T1		See OutTypes	0	100	2

40178		LCD Custom screen 2 - Line 1	T1		See OutTypes	0	100	2
40179		LCD Custom screen 2 - Line 2	T1		See OutTypes	0	100	2
40180		LCD Custom screen 2 - Line 3	T1		See OutTypes	0	100	2
40181		LCD Custom screen 3 - Line 1	T1		See OutTypes	0	100	2
40182		LCD Custom screen 3 - Line 2	T1		See OutTypes	0	100	2
40183		LCD Custom screen 3 - Line 3	T1		See OutTypes	0	100	2
40184		LCD scroll parameters 1	T1	Bit 0	Counter n1 (Allways)	1	65535	2
				Bit 1	Counter n2			
				Bit 2	Counter n3			
				Bit 3	Counter n4			
40185		LCD scroll parameters 2		Bit 0..7	Counter 1 .. 8	0	65535	2
				Bit 8..15	Counter 9 .. 16			
40186		LCD scroll parameters 3		Bit 0	Active Power Total (Pt)	0	65535	2
				Bit 1	Active Power P1 .. P3 (P12)			
				Bit 2	Reactive Power Total (Qt)			
				Bit 3	Reactive Power Q1 .. Q3 (Q12)			
				Bit 4	Apparent Power Total (St)			
				Bit 5	Apparent Power S1 .. S3 (S12)			
				Bit 6	Uavg (phase to neutral)			
				Bit 7	Voltage U1 .. U3			
				Bit 8	Uavg (phase to phase)			
				Bit 9	Voltage U12 .. U31			
				Bit 10	Curent Total			
				Bit 11	Curent I1 .. I3 (I12)			
				Bit 12	Frequency			
				Bit 13	Active Tariff			
				Bit 14	Power Factor Total (PFt)			
				Bit 15	Power Factor PF1 .. PF3 (PF12)			
40187		LCD scroll parameters 4		Bit 0	Power Angle Total (atan2(Pt,Qt))	0	31	2
				Bit 1	Power Angle 1 .. 3 (12)			
				Bit 2	THD of voltage			
				Bit 3	THD of current			
				Bit 4	Clock			
40188		LCD return mode	T1	0	Auto scroll	0	2	2
40192		Comm. & LCD average interval	T1		10=1,0 sec	0,1	5,0	2
40193		Touch Key Control	T1	Bit 0	Touch Key Lock enable	0	1	2



Address	Contents	Data	Ind	Values	min	max	P. Level	
<b>COMMUNICATION</b>								
40202	Port 1: Device Adress (Modbus)	T1			1	247	2	
40203	Port 1: Boud Rate	T1	0	Baud rate 1200	1	7	2	
			1	Baud rate 2400				
			2	Baud rate 4800				
			3	Baud rate 9600				
			4	Baud rate 19200				
			5	Baud rate 38400				
			6	Baud rate 57600				
7	Baud rate 115200							
40204	Port 1: Stop Bit	T1	0	1 Stop bit	0	1	2	
			1	2 Stop bits				
40205	Port 1: Parity	T1	0	No parity	0	2	2	
			1	Odd parity				
			2	Even parity				
40206	Port 1: Data Bits	T1	0	8 bits	0	0	2	
			1	7 bits				
40207	Port 1: TCP Port	T1			1	65535	2	
40208	40227	Port 1: IP Host name	T_Str40				2	
40228	40229	Port 1: IP Address	T_Hex4				0	
40230	40231	Port 1: Subnet Mask	T_Hex4				0	
40232	40233	Port 1: Default Router	T_Hex4				2	
40234	40241	WIFI password	T_Str16				2	
40242	40249	WIFI SSID	T_Str16				2	
40250	Bluetooth ON/OFF	T1	0	Off			2	
			1	On				
<b>IR</b>								
40251	res. for Port 2: Device Address (DNP3)	T1			0	65519	2	
40252	Port 2: Device Adress (Modbus)	T1			1	247	2	
40253	Port 2: Boud Rate	T1		see Port 1: Boud Rate	3	7	2	
40254	Port 2: Stop Bit	T1		see Port 1: Stop Bit	0	1	2	
40255	Port 2: Parity	T1		see Port 1: Parity	0	2	2	
40256	Port 2: Data Bits	T1		see Port 1: Data Bits	0	0	2	
40257	40270	Reserved						
<b>M-bus</b>								
40271	M-bus Primary address	T1			0	250	2	
40272		T1	0	Baud rate 300	1	5	2	
			1	Baud rate 600				
			2	Baud rate 1200				
			3	Baud rate 2400				
			4	Baud rate 4800				
5	Baud rate 9600							
40273	40274	M-bus Secondary address	T3		Digits only (Default = Serial number)	0	99999999	2
40202		Port 1: Device Adress (Modbus)	T1			1	247	2
40203			T1	0	Baud rate 1200	1	7	2
				1	Baud rate 2400			
				4	Baud rate 4800			
				5	Baud rate 9600			
40273	40274	M-bus Secondary address	T3		Digits only (Default = Serial number)	0	99999999	2

Address	Contents	Data	Ind	Values	min	max	P. Level
<b>ENERGY</b>							
40401	Active Tariff	T1	0	Tariff input	0	6	1
			1..4	Tariff 1..4			
			5..6	Tariff 5..6			
40402	Common Energy Counter Exponent	T2			-3	4	2
40403	40418	Reserved					
40419	Total Energy Calculation	T1	0	Evaluation of the sum of phases	0	1	2
			1	Evaluation of individual phases			
40420	Reactive power calculation	T1	0	Standard calculation ( $Q^2=S^2-P^2$ )	0	1	2
			1	Delayed Current method			
<b>NON-RESETABLE COUNTERS</b>							
40421	Energy Counter n1 Parameter	T1	0	No Parameter	0	95	2
			1	Active Power			
			2	Reactive power			
			3	Apparent Power			
			5	Active Power Phase 1			
			6	Reactive power Phase 1			
			7	Apparent Power Phase 1			
			9	Active Power Phase 2			
			10	Reactive power Phase 2			
			11	Apparent Power Phase 2			
			13	Active Power Phase 3			
			14	Reactive power Phase 3			
			15	Apparent Power Phase 3			
			33	Active Power individual phases			
34	Reactive Power individual phases						
35	Apparent Power individual phases						
40422	Energy Counter n1 Configuration	T1	Bit-0	Quadrant I Enabled	0	63	2
			Bit-1	Quadrant II Enabled			
			Bit-2	Quadrant III Enabled			
			Bit-3	Quadrant IIII Enabled			
			Bit-4	Absolute Value			
			Bit-5	Invert Value			
40423	Energy Counter n1 Exponent	T2			-3	6	2
40424	Energy Counter n1 Tarif Selector	T1	Bit-0	Tarif 1 Enabled	0	63	2
			Bit-1	Tarif 2 Enabled			
			Bit-2	Tarif 3 Enabled			
			Bit-3	Tarif 4 Enabled			
			Bit-4	Tarif 5 Enabled			
			Bit-5	Tarif 6 Enabled			
40425	Energy Counter n2 Parameter	T1		see Energy Counter n1 Parameter	0	95	2

40426	Energy Counter n2 Configuration	T1		see Energy Counter n1 Configuration	0	63	2
40427	Energy Counter n2 Exponent	T2		see Energy Counter n1 Exponent	-3	6	2
40428	Energy Counter n2 Tarif Selector	T1		see Energy Counter n1 Tarif Selector	0	63	2
40429	Energy Counter n3 Parameter	T1		see Energy Counter n1 Parameter	0	95	2
40430	Energy Counter n3 Configuration	T1		see Energy Counter n1 Configuration	0	63	2
40431	Energy Counter n3 Exponent	T2		see Energy Counter n1 Exponent	-3	6	2
40432	Energy Counter n3 Tarif Selector	T1		see Energy Counter n1 Tarif Selector	0	63	2
40433	Energy Counter n4 Parameter	T1		see Energy Counter n1 Parameter	0	95	2
40434	Energy Counter n4 Configuration	T1		see Energy Counter n1 Configuration	0	63	2
40435	Energy Counter n4 Exponent	T2		see Energy Counter n1 Exponent	-3	6	2
40436	Energy Counter n4 Tarif Selector	T1		see Energy Counter n1 Tarif Selector	0	63	2
	<b>RESETABLE COUNTERS</b>						
40437	Energy Counter 1 Parameter	T1		see Energy Counter n1 Parameter	0	95	2
40438	Energy Counter 1 Configuration	T1		see Energy Counter n1 Configuration	0	63	2
40439	Energy Counter 1 Exponent	T2		see Energy Counter n1 Exponent	-3	6	2
40440	Energy Counter 1 Tarif Selector	T1		see Energy Counter n1 Tarif Selector	0	63	2
40441	Energy Counter 2 Parameter	T1		see Energy Counter n1 Parameter	0	95	2
40442	Energy Counter 2 Configuration	T1		see Energy Counter n1 Configuration	0	63	2
40443	Energy Counter 2 Exponent	T2		see Energy Counter n1 Exponent	-3	6	2
40444	Energy Counter 2 Tarif Selector	T1		see Energy Counter n1 Tarif Selector	0	63	2
40445	Energy Counter 3 Parameter	T1		see Energy Counter n1 Parameter	0	95	2
40446	Energy Counter 3 Configuration	T1		see Energy Counter n1 Configuration	0	63	2
40447	Energy Counter 3 Exponent	T2		see Energy Counter n1 Exponent	-3	6	2
40448	Energy Counter 3 Tarif Selector	T1		see Energy Counter n1 Tarif Selector	0	63	2
40449	Energy Counter 4 Parameter	T1		see Energy Counter n1 Parameter	0	95	2
40450	Energy Counter 4 Configuration	T1		see Energy Counter n1 Configuration	0	63	2

40451		Energy Counter 4 Exponent	T2		see Energy Counter n1 Exponent	-3	6	2
40452		Energy Counter 4 Tarif Selector	T1		see Energy Counter n1 Tarif Selector	0	63	2
40453		Energy Counter 5 Parameter	T1		see Energy Counter n1 Paramete	0	95	2
40454		Energy Counter 5 Configuration	T1		see Energy Counter n1 Configuration	0	63	2
40455		Energy Counter 5 Exponent	T2		see Energy Counter n1 Exponent	-3	6	2
40456		Energy Counter 5 Tarif Selector	T1		see Energy Counter n1 Tarif Selector	0	63	2
40457		Energy Counter 6 Parameter	T1		see Energy Counter n1 Parameter	0	95	2
40458		Energy Counter 6 Configuration	T1		see Energy Counter n1 Configuration	0	63	2
40459		Energy Counter 6 Exponent	T2		see Energy Counter n1 Exponent	-3	6	2
40460		Energy Counter 6 Tarif Selector	T1		see Energy Counter n1 Tarif Selector	0	63	2
40461		Energy Counter 7 Parameter	T1		see Energy Counter n1 Parameter	0	95	2
40462		Energy Counter 7 Configuration	T1		see Energy Counter n1 Configuration	0	63	2
40463		Energy Counter 7 Exponent	T2		see Energy Counter n1 Exponent	-3	6	2
40464		Energy Counter 7 Tarif Selector	T1		see Energy Counter n1 Tarif Selector	0	63	2
40465		Energy Counter 8 Parameter	T1		see Energy Counter n1 Parameter	0	95	2
40466		Energy Counter 8 Configuration	T1		see Energy Counter n1 Configuration	0	63	2
40467		Energy Counter 8 Exponent	T2		see Energy Counter n1 Exponent	-3	6	2
40468		Energy Counter 8 Tarif Selector	T1		see Energy Counter n1 Tarif Selector	0	63	2
40469	40472	Energy Counter 9			see Energy Counter n1			2
40473	40476	Energy Counter 10			see Energy Counter n1			2
40477	40480	Energy Counter 11			see Energy Counter n1			2
40481	40484	Energy Counter 12			see Energy Counter n1			2
40485	40488	Energy Counter 13			see Energy Counter n1			2
40489	40492	Energy Counter 14			see Energy Counter n1			2
40493	40496	Energy Counter 15			see Energy Counter n1			2
40497	40500	Energy Counter 16			see Energy Counter n1			2

## SUPPORTED FUNCTIONS AND USAGE

Code DEC	Code HEX	FUNCTION	REFERENCES
3	03	to read from holding registers	(4XXXX memory references)
4	04	to read from input registers	(3XXXX memory references)
6	06	to write to a single holding register	(4XXXX memory references)
16	10	to write to one or more holding register	(4XXXX memory references)

## DATA TYPES DECODING

Registers defined in the Modbus database will define data as one of the data types described in the following table:

TYPE	VALUE / BIT MASK	DESCRIPTION
T1		Unsigned Value (16 bit) Example: 12345 stored as 12345 = 3039 <sub>(16)</sub>
T2		Signed Value (16 bit) Example: -12345 stored as -12345 = CFC7 <sub>(16)</sub>
T3		Signed Long Value (32 bit) Example: 123456789 stored as 123456789 = 075B CD 15 <sub>(16)</sub>
T4	bits # 15..14 bits # 13..00	Short Unsigned float (16 bit) Decade Exponent(Unsigned 2 bit) Binary Unsigned Value (14 bit) Example: 10000*10 <sup>2</sup> stored as A710 <sub>(16)</sub>
T5	bits # 31..24 bits # 23..00	Unsigned Measurement (32 bit) Decade Exponent(Signed 8 bit) Binary Unsigned Value (24 bit) Example: 123456*10 <sup>-3</sup> stored as FD01 E240 <sub>(16)</sub>
T6	bits # 31..24 bits # 23..00	Signed Measurement (32 bit) Decade Exponent (Signed 8 bit) Binary Signed value (24 bit) Example: - 123456*10 <sup>-3</sup> stored as FDFE 1DC0 <sub>(16)</sub>
T7	bits # 31..24 bits # 23..16 bits # 15..00	Power Factor (32 bit) Sign: Import/Export (00/FF) Sign: Inductive/Capacitive (00/FF) Unsigned Value (16 bit), 4 decimal places Example: 0.9876 CAP stored as 00FF 2694 <sub>(16)</sub>
T8	bits # 31..24 bits # 23..16 bits # 15..08 bits # 07..00	Time stamp (32 bit) Minutes 00 - 59 (BCD) Hours 00 - 23 (BCD) Day of month 01 - 31 (BCD) Month of year 01 - 12 (BCD) Example: 15:42, 1. SEP stored as 4215 0109 <sub>(16)</sub>
T9	bits # 31..24 bits # 23..16 bits # 15..08 bits # 07..00	Time (32 bit) 1/100s 00 - 99 (BCD) Seconds 00 - 59 (BCD) Minutes 00 - 59 (BCD) Hours 00 - 24 (BCD) Example: 15:42:03.75 stored as 7503 4215 <sub>(16)</sub>
T10	bits # 31..24 bits # 23..16 bits # 15..00	Date (32 bit) Day of month 01 - 31 (BCD) Month of year 01 - 12 (BCD) Year (unsigned integer) 1998..4095 Example: 10, SEP 2000 stored as 1009 07D0 <sub>(16)</sub>
T_Str4 (T11)		Text String 4 characters Two characters per 16 bit register
T_Str6 (T12)		Text String 6 characters Two characters per 16 bit register
T_Str8		Text String 8 characters Two characters per 16 bit register.
T_Str16		Text String 16 characters Two characters per 16 bit register.
T_Str20		Text String 20 characters Two characters per 16 bit register.
T16		Unsigned Value (16 bit), 2 decimal places Example: 123.45 stored as 123.45 = 3039 <sub>(16)</sub>
T17		Signed Value (16 bit), 2 decimal places Example: -123.45 stored as -123.45 = CFC7 <sub>(16)</sub>

TYPE	VALUE / BIT MASK	DESCRIPTION
T_Time	bits # 63..56 bits # 55..48 bits # 47..40 bits # 39..32 bits # 31..24 bits # 23..16 bits # 15..00	Time and Date (64 bit) 1/100s 00 - 99 (BCD) Seconds 00 - 59 (BCD) Minutes 00 - 59 (BCD) Hours 00 - 24 (BCD) Day of month 01 - 31 (BCD) Month of year 01 - 12 (BCD) Year (unsigned integer) 1998..4095 Example: 15:42:03.75, 10. SEP 2000 stored as 7503 4215 1009 07D0 <sub>(16)</sub>
T_TimeIEC	bits # 63..55 bits # 54..48 bits # 47..44 bits # 43..40 bits # 39..37 bits # 36..32 bit # 31 bits # 30..29 bits # 28..24 bit # 23 bit # 22 bits # 21..16 bits # 15..00	Time and Date (64 bit) = IEC870-5-4 "Binary Time 2a" Reserved Years (0 .. 99) Reserved Months (1 .. 12) Day of Week (1 .. 7) Day of Month (1 .. 31) Summer Time (0 .. 1): Summer time (1), Standard time (0) Reserved Hours (0 .. 23) Invalid (0 .. 1): Invalid (1), Valid (0) Reserved Minutes (0 .. 59) Milliseconds (0 .. 59999) Example: 15:42, 1. SEP stored as 4215 0109 <sub>(16)</sub>
T_Data		Record Data Size and SubTypes depends on the Actual Memory Part
T_Str40		Text String 40 characters Two characters per 16 bit register.
T_float	bits # 31 bits # 30..23 bits # 22..0	IEEE 754 Floating-Point Single Precision Value (32 bit) Sign Bit (1 bit) Exponent Field (8 bit) Significand (23 bit) Example: 123.45 stored as 123.45000 = 42F6 E666 <sub>(16)</sub>
T9A	bits # 15..08 bits # 07..00	Time (16 bit) Minutes 00 - 59 (BCD) Hours 00 - 24 (BCD) Example: 15:42 stored as 4215 <sub>(16)</sub>
T10A	bits # 15..08 bits # 07..00	Date (16 bit) Day of month 00 - 31 (BCD) Month of year 00 - 12 (BCD) Example: 30, SEP stored as 3009 <sub>(16)</sub>
T18		Signed Value (16 bit), 4 decimal places Example: -0.2345 stored as -2345 = F6D7 <sub>(16)</sub>
T_unix	Bits # 31..00	Unix time (32 bit) Seconds since January 1, 1970 Example: 16 May 2012 10:36:46 GMT stored as 4FB3 833E <sub>(16)</sub>

## APPENDIX B: M-BUS

The M-BUS interface fully complies with M-BUS European standard EN13757-2. The entire communication is ensured with 8 Data Bits, Even Parity, 1 Stop Bit and a Baud Rate from 300 to 9600 Bauds.

### COMMUNICATION SETTINGS

Default communication settings are: 2400, 8, E, 1 primary address 0 and secondary address is set to serial number of device.

### INITIALIZE M-BUS (SNK\_NKE)

This Short Telegram initializes the M-BUS 7M.38.8.400.XXXX.

The M-BUS 7M.38.8.400.XXXX confirms correct receipt by Single Character Acknowledgement (ACK = E5).

If the telegram was not correctly received the 7M.38.8.400.XXXX will not send an acknowledgement.

### SELECT M-BUS 7M.38.8.400.XXXX USING SECONDARY ADDRESS (SND\_UD)

This Telegram enables to select M-BUS 7M.38.8.400.XXXX. The M-BUS 7M.38.8.400.XXXX confirms the correct receipt by ACK.

If the telegram has not been correctly received the M-BUS 7M.38.8.400.XXXX will not send an Acknowledgement.

After issue of the Single Character Acknowledgement the M-BUS 7M.38.8.400.XXXX is ready to transmit the entire Read-out Data within 3 seconds from receiving the Telegram „Transmit Read-out Data“.

At the end of 3 seconds the M-BUS 7M.38.8.400.XXXX will switch back to normal mode.

### TRANSMIT READ-OUT DATA VIA PRIMARY/SECONDARY ADDRESS (REQ\_UD2)

This Short Telegram enables to select the M-BUS 7M.38.8.400.XXXX and to command it to transmit the Read-out Data parameterized. The M-BUS 7M.38.8.400.XXXX confirms correct receipt by transmitting of the Read-out Data.

If the Short Telegram has not been received correctly; no Data will be transmitted by the M-BUS 7M.38.8.400.XXXX.

The Read-out Data are sent within 35 ms – 75 ms from receipt of the Short Telegram by the M-BUS Meter (for more informations see section M-Bus telegrams).

### SET BAUD RATE VIA PRIMARY/SECONDARY ADDRESS (SND\_UD)

This telegram enables to set the desired Baud Rate. The M-BUS 7M.38.8.400.XXXX confirms the correct receipt by ACK.

If the telegram was not received correctly the M-BUS 7M.38.8.400.XXXX does not send an Acknowledgement.

The (ACK) is sent by the M-BUS 7M.38.8.400.XXXX in the Old Baud Rate. As soon as ACK is transmitted the M-BUS Meter switches to the baud rate newly parameterized. If the 7M.38.8.400.XXXX now does not receive a new Telegram under the new baud rate within a period of 30 seconds – 40 seconds, it automatically switches back to the old baud rate.

This is apt to prevent that a faulty setting of the baud rate may interrupt communication.

### SET PRIMARY ADDRESS VIA PRIMARY/SECONDARY ADDRESS (SND\_UD)

This Telegram enables to set a new Primary Address. The M-BUS 7M.38.8.400.XXXX confirms the correct receipt by ACK.

If the telegram has not been correctly received the M-BUS 7M.38.8.400.XXXX will not send an Acknowledgement.

### SET SECONDARY ADDRESS VIA PRIMARY/SECONDARY ADDRESS (SND\_UD)

This Telegram enables to set a new Secondary Address. The M-BUS 7M.38.8.400.XXXX confirms the correct receipt by ACK.

If the telegram has not been correctly received the M-BUS 7M.38.8.400.XXXX will not send an Acknowledgement.

Secondary Address (UD) consists of:

Identification Number:	00000000 – 99999999	8-digit Secondary Address number
Manufacturer's Code:	73 26	2 Byte Company Constant (ISS = "73 26")
Version Number:	01 – FF	1 Byte
Medium: 02	1 Byte Constant Electricit	

**RESET, RESTART M-BUS MC350 VIA PRIMARY/SECONDARY ADDRESS (SND\_UD)**

This Telegram reset/restarts M-BUS MC350. The M-BUS 7M.38.8.400.XXXX confirms correct receipt by ACK.

If the telegram was not correctly received the M-BUS 7M.38.8.400.XXXX will not send an acknowledgement.

**M-BUS TELEGRAM****TOTAL ENERGY COUNTERS 0, 1, 2, 3**

Energy counters could represent: +/- active energy, +/-reactive energy or apparent energy and one of 4-th tariff.

	DIF	DIFE	DIFE	VIF	VIFE	VIFE	VIFE	DATA
								xx.xx.xx.xx
T0:	04	none	none					
T1:	84	10	none					
T2:	84	20	none					
A+:				05	none	none	none	*10 <sup>5-3</sup> Wh
A-:				85	3C	none	none	*10 <sup>5-3</sup> Wh
R+:				FB	82	75	none	*10 <sup>5-3</sup> varh
R-:				FB	82	F5	3C	*10 <sup>5-3</sup> varh
App:				FB	84	75	none	*10 <sup>5-3</sup> VAh

**ACTIVE TARIFF NUMBER**

Tariff number in progress (1 to 4)

DIF	DIFE	DIFE	VIF	VIFE	VIFE	VIFE	DATA
01			FF	01			xx

DATA: value represent as 8-bit integer

**ACTIVE POWER TOTAL PT (W)**

Active power total in 32 bit  $\times 10^{(2-3)}$  W

DIF	DIFE	DIFE	VIF	VIFE	DATA
04			2A	01	xx.xx.xx.xx

**ACTIVE POWER TOTAL (KVAR)**

Reactive power total in 32bit  $\times 10^{(2-3)}$  var

DIF	DIFE	VIF	VIFE	VIFE	VIFE	DATA
04		FB	97	72		xx.xx.xx.xx

**INSTANT APPARENT POWER TOTAL (VA)**

Apparent power total in 32 bit  $\times 10^{(5-6)}$  VA

DIF	DIFE	VIF	VIFE	VIFE	VIFE	DATA
04		FB	B4	75		xx.xx.xx.xx

n - 0...7

**POWER FACTOR: -: LEADING ET +: LAGGING: PF**

Power factor as 32-bit integer  $\times 10^{-3}$

DIF	DIFE	DIFE	VIF	VIFE	VIFE	VIFE	DATA
04			A8	B4	35		xx.xx.xx.xx

Unit : W/V/A



## CURRENT TOTAL (A)

Total current as 32 bit x 10<sup>(9-12)</sup> A

DIF	DIFE	VIF	VIFE	VIFE	DATA
04		FD	59		xx.xx.xx.xx

## SYSTEM FREQUENCY (HZ/1000)

Contains the line frequency 32-bit integer in mHz.

DIF	DIFE	DIFE	VIF	VIFE	VIFE	VIFE	DATA
04			FB	2C			xx.xx.xx.xx

## ACTIVE POWER IN PHASE 1, 2, 3 (W)

Active power in 32bit x 10<sup>(2-3)</sup> W

	DIF	DIFE	DIFE	VIF	VIFE	VIFE	DATA
	04						xx.xx.xx.xx

P1:

AA

FC

01

P2:

AA

FC

02

P3:

AA

FC

03

## CURRENT IN PHASE 1, 2, 3, NEUTRAL (A)

Phase current as 32 bit x 10<sup>(9-12)</sup> A

	DIF	DIFE	VIF	VIFE	VIFE	VIFE	DATA
	04						xx.xx.xx.xx

I1:

FD

D9

FC

01

I2:

FD

D9

FC

02

I3:

FD

D9

FC

03

## VOLTAGES (V)

Voltage as 32 bit x 10<sup>(7-9)</sup> V

	DIF	DIFE	VIF	VIFE	VIFE	VIFE	DATA
	04						xx.xx.xx.xx

U1:

FD

C7

FC

01

U2:

FD

C7

FC

02

U3:

FD

C7

FC

03

U12:

FD

C7

FC

05

U23:

FD

C7

FC

06

U31:

FD

C7

FC

07

## APPENDIX C: EQUATIONS

NUMBER	SYMBOL	DEFINITION
1	MP	Average interval
2	$U_f$	Phase voltage ( $U_1, U_2$ or $U_3$ )
3	$U_{ff}$	Phase-to-phase voltage ( $U_{12}, U_{23}$ or $U_{31}$ )
4	N	Total number of samples in a period
5	n	Sample number ( $0 \leq n \leq N$ )
6	x, y	Phase number (1, 2 or 3)
7	$i_n$	Current sample n
8	$U_{fn}$	Phase voltage sample n
9	$U_{ffn}$	Phase-to-phase voltage sample n
10	$\phi_f$	Power angle between current and phase voltage f ( $\phi_1, \phi_2$ or $\phi_3$ )

### VOLTAGE

$$U_f = \sqrt{\frac{\sum_{n=1}^N u_n^2}{N}}$$

**Phase voltage**  
samples in averaging interval (up to 65 Hz)

$$U_{xy} = \sqrt{\frac{\sum_{n=1}^N (u_{xn} - u_{yn})^2}{N}}$$

**Phase-to-phase voltage**  
 $u_x, u_y$  – phase voltages ( $U_f$ )  
N – a number of samples in averaging interval

### CURRENT

$$I_{\text{TRMS}} = \sqrt{\frac{\sum_{n=1}^N i_n^2}{N}}$$

**Phase current**  
N – samples in averaging interval (up to 65 Hz)

## POWER

$P_f = \frac{1}{N} \sum_{n=1}^N (u_{fn} \times i_{fn})$	<p><b>Active power by phases</b>            N – a number of periods            n – index of sample in a period            f – phase designation</p>
$P_t = P_1 + P_2 + P_3$	<p><b>Total active power</b>            t – total power            1, 2, 3 – phase designation</p>
<p>SignQ6(<math>\varphi</math>)  <math>\varphi \in [0^\circ - 180^\circ] \rightarrow \text{SignQ}^*(\varphi) = +1</math>  <math>\varphi \in [180^\circ - 360^\circ] \rightarrow \text{SignQ}^*(\varphi) = -1</math></p>	<p>Reactive power sign            Qf – reactive power (by phases)  <math>\varphi</math> – power angle</p>
$S = U_f \cdot I_f$	<p><b>Apparent power by phases</b>            Uf – phase voltage            If – phase current</p>
$S_t = S_1 + S_2 + S_3$	<p><b>Total apparent power</b>            St – apparent power by phases</p>
$Q_f = \text{SignQ}(\varphi) \times \sqrt{S_f^2 - P_f^2}$	<p><b>Reactive power by phases</b>            Sf – apparent power by phases            Pf – active power by phases</p>
$Q_f = \frac{1}{N} \cdot \sum_{n=1}^N (u_{fn} \times i_{f[n+N/4]})$	<p><b>Reactive power by phases (displacement method)</b>            N – a number of samples in a period            n – sample number (<math>0 \leq n \leq N</math>)            f – phase designation</p>
$Q_t = Q_1 + Q_2 + Q_3$	<p><b>Total reactive power</b>            Qt – reactive power by phases</p>
<p><math>\varphi_s = \arctan2(P_f, Q_f)</math>  <math>\varphi_s = [-180^\circ, 179,99^\circ]</math></p>	<p><b>Total power angle</b>            Pt – total active power            Qt – total reactive power</p>
$PF = \frac{ P }{S}$	<p><b>Distortion power factor</b>            P – active power            S – apparent power</p>
<h2>THD</h2>	
$I_f \text{ THD}(\%) = \frac{\sqrt{\sum_{n=2}^{63} I_{fn}^2}}{I_{f1}} 100$	<p><b>Current THD</b>            I1 – value of first harmonic            n – number of harmonic</p>
$U_f \text{ THD}(\%) = \frac{\sqrt{\sum_{n=2}^{63} U_{fn}^2}}{U_{f1}} 100$	<p><b>Phase voltage THD</b>            U1 – value of first harmonic            n – number of harmonic</p>

