

Total solder points: 107

Difficulty level: *beginner* 1 2 3 4 5 *advanced*

USB to RF remote control transmitter

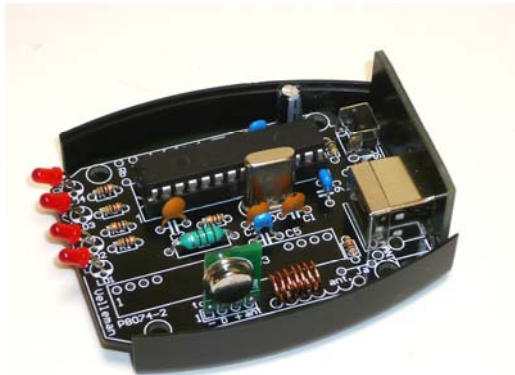

K8074

Turn your computer into a powerful remote control

The transmitter works together with our K8056 card, equipped with an RX433N receiver module. Also our K8070 / VM119 one channel receiver can be used. In total a combination of 255 cards can be addressed, resulting in a maximum of 2040 channels !!

Drivers and example software can be downloaded from our web site.
A DLL is provided to create your own application.

Specifications:

- USB1.1 or 2.0 port compliant
- up to 30m (depends on environment)
- works with K8056 (+RX433N) and K8070 / VM119
- RF transmit indicator LED
- power LED
- USB port function LED's
- 255 selectable addresses
- transmit—test button
- 433MHz transmitter
- R&TTE compliant design
- power supply: USB
- dimensions: 80x55x35mm / 3,14x2,16x1,37"

1. Assembly (Skipping this can lead to troubles !)

Ok, so we have your attention. These hints will help you to make this project successful. Read them carefully.

1.1 Make sure you have the right tools:

- A good quality soldering iron (25-40W) with a small tip.
- Wipe it often on a wet sponge or cloth, to keep it clean; then apply solder to the tip, to give it a wet look. This is called 'thinning' and will protect the tip, and enables you to make good connections. When solder rolls off the tip, it needs cleaning.
- Thin raisin-core solder. Do not use any flux or grease.
- A diagonal cutter to trim excess wires. To avoid injury when cutting excess leads, hold the lead so they cannot fly towards the eyes.
- Needle nose pliers, for bending leads, or to hold components in place.
- Small blade and Phillips screwdrivers. A basic range is fine.

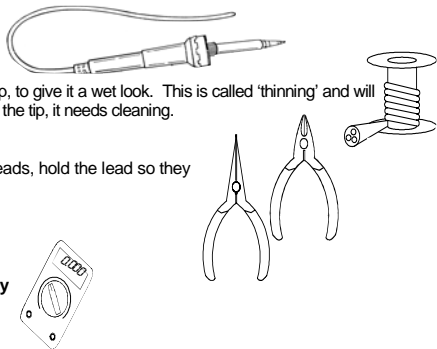

For some projects, a basic multi-meter is required, or might be handy

1.2 Assembly Hints :

- ⇒ Make sure the skill level matches your experience, to avoid disappointments.
- ⇒ Follow the instructions carefully. Read and understand the entire step before you perform each operation.
- ⇒ Perform the assembly in the correct order as stated in this manual
- ⇒ Position all parts on the PCB (Printed Circuit Board) as shown on the drawings.
- ⇒ Values on the circuit diagram are subject to changes.
- ⇒ Values in this assembly guide are correct*
- ⇒ Use the check-boxes to mark your progress.
- ⇒ Please read the included information on safety and customer service

* Typographical inaccuracies excluded. Always look for possible last minute manual updates, indicated as 'NOTE' on a separate leaflet.

1.3 Soldering Hints :

1- Mount the component against the PCB surface and carefully solder the leads

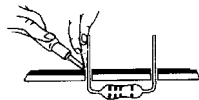

2- Make sure the solder joints are cone-shaped and shiny

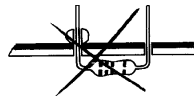
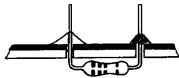

3- Trim excess leads as close as possible to the solder joint

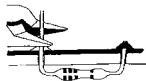

REMOVE THEM FROM THE TAPE ONE AT A TIME !

**AXIAL COMPONENTS ARE TAPED IN THE
CORRECT MOUNTING SEQUENCE !**

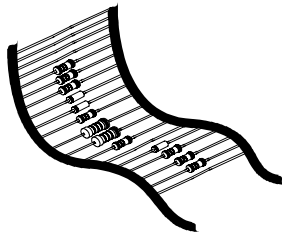

Break the PCB into 2 pieces

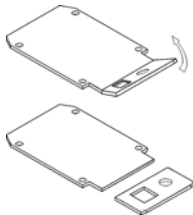

1. Resistors

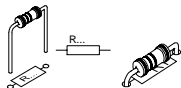

- R1 : 1K (1 - 0 - 2 - B)
- R2 : 1K (1 - 0 - 2 - B)
- R3 : 1K (1 - 0 - 2 - B)
- R4 : 1K (1 - 0 - 2 - B)
- R5 : 10K (1 - 0 - 3 - B)
- R6 : 10 (1 - 0 - 0 - B)
- R7 : 10 (1 - 0 - 0 - B)
- R8 : 10 (1 - 0 - 0 - B)
- R9 : 1K (1 - 0 - 2 - B)

2. Coil

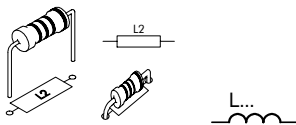

- L1 : 100 μ H (1 - 0 - 1 - A)

3. IC socket, Watch the position of the notch!

- IC1 : 28P

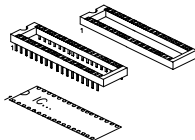

4. Capacitors

- C1 : 22pF (22)
- C2 : 22pF (22)
- C3 : 10nF (103)
- C4 : 100nF (104)
- C5 : 100nF (104)
- C6 : 220nF (224)

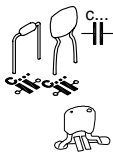

5. Push button

- SW1 : Test



6. Electrolytic Capacitor. Watch the polarity !

- C7 : 4,7 μ F

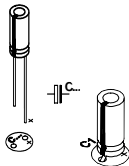

7. LEDs. Watch the polarity!

- LD1 : 3mm RED 'USB'
- LD2 : 3mm RED 'USB'
- LD3 : 3mm RED 'RX/TX'
- LD4 : 3mm RED 'ON'



Mount the LEDs vertically and bend so they will be visible through the window in the housing.

8. USB connector

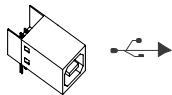

- SK1

9. Quartz crystal

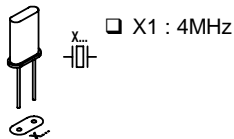

10. Transmitter module

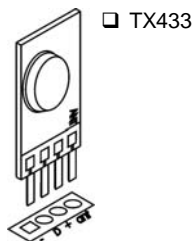

The "ANT" connection will match the markings on the PCB. Refer to the illustration or package.

11. IC, watch the position of the notch!

- IC1 : VK8074
programmed PIC18F2450-I/SP

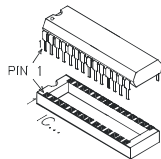

12. ASSEMBLING THE ANTENNA

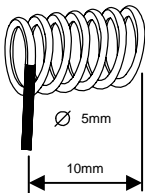

IMPORTANT:

Construct the antenna coil as described to make sure it complies with the effective R&TTE directive.

Wind the antenna using the included copper wire.

Remove the lacquer from one side of the wire with a knife so the solder will hold.

Wind the antenna using a Ø 5mm drill bit (NOT 4mm or 6mm).

Make 7 windings and elongate until the antenna is 10mm long (*see fig. and picture on the packaging*).

Solder the coil in place.

13. TEST

Refer to the user manual *

* Download the user manual from www.vellemanprojects.com

14. Assembly

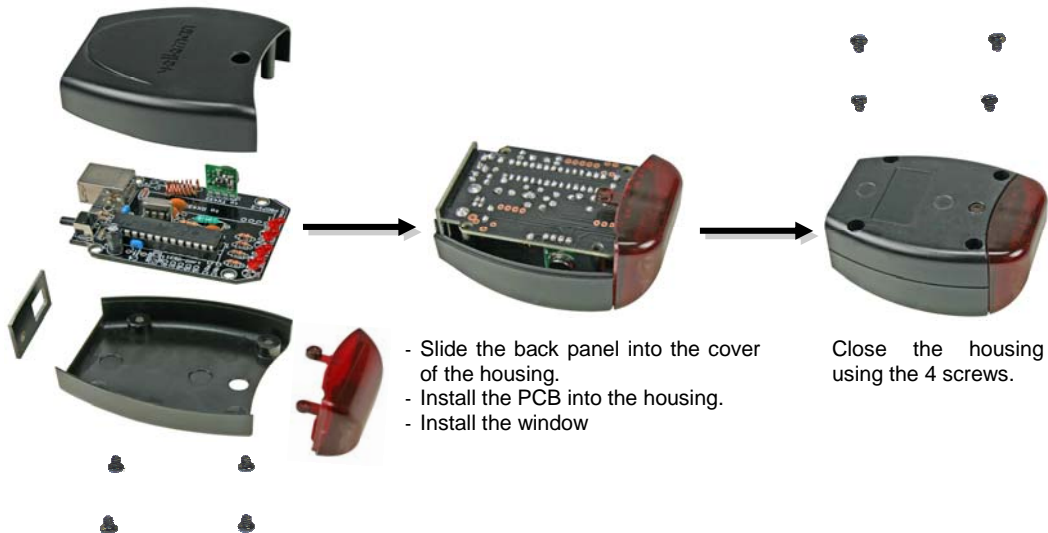

- Slide the back panel into the cover of the housing.
- Install the PCB into the housing.
- Install the window

Close the housing using the 4 screws.

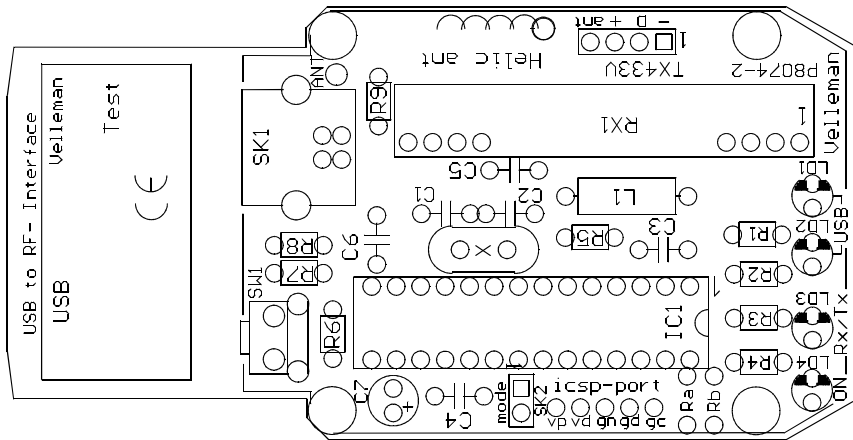



VELLEMAN Components NV
Legen Heirweg 33
9890 Gavere
Belgium Europe
www.velleman.be
www.velleman-kit.com

Modifications and typographical errors reserved
© Velleman Components nv.
H8074IP'1 - 2008

