

Total solder points: 55

Difficulty level: *beginner* 1  2  3  4  5  *advanced*

## RELAY OUTPUT MODULE FOR K8006

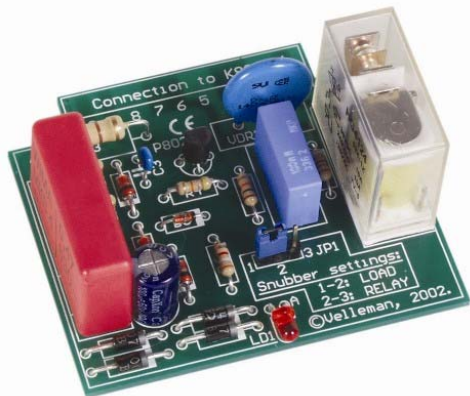

# K8027

Switching lamps or other domestic loads.

### Features:

- For use with K8006 Base unit for home modular light system.
- Suited for both resistive and inductive loads.
- Can be operated from an external push button & open collector trough : ex. K8000 - K8023 - K8046 - K8050
- Control LED.

### Specifications:

- Operating voltage : 110 to 240Vac (50/60Hz).
- Max Load : 2,5A (275W/110V - 575W/230V).
- Dimensions : 65 x 57 x 25mm / 2,6" x 2,2" x 1"

### 1. Assembly (Skipping this can lead to troubles !)

Ok, so we have your attention. These hints will help you to make this project successful. Read them carefully.

#### 1.1 Make sure you have the right tools:

- A good quality soldering iron (25-40W) with a small tip.
- Wipe it often on a wet sponge or cloth, to keep it clean; then apply solder to the tip, to give it a wet look. This is called 'thinning' and will protect the tip, and enables you to make good connections. When solder rolls off the tip, it needs cleaning.
- Thin rosin-core solder. Do not use any flux or grease.
- A diagonal cutter to trim excess wires. To avoid injury when cutting excess leads, hold the lead so they cannot fly towards the eyes.
- Needle nose pliers, for bending leads, or to hold components in place.
- Small blade and Phillips screwdrivers. A basic range is fine.

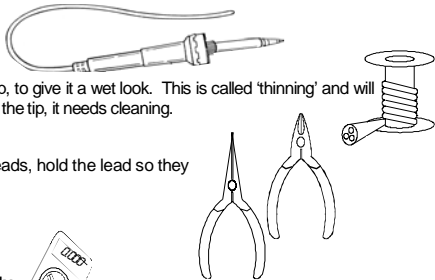

**For some projects, a basic multi-meter is required, or might be handy**



#### 1.2 Assembly Hints :

- ⇒ Make sure the skill level matches your experience, to avoid disappointments.
- ⇒ Follow the instructions carefully. Read and understand the entire step before you perform each operation.
- ⇒ Perform the assembly in the correct order as stated in this manual
- ⇒ Position all parts on the PCB (Printed Circuit Board) as shown on the drawings.
- ⇒ Values on the circuit diagram are subject to changes.
- ⇒ Values in this assembly guide are correct\*
- ⇒ Use the check-boxes to mark your progress.
- ⇒ Please read the included information on safety and customer service

\* Typographical inaccuracies excluded. Always look for possible last minute manual updates, indicated as 'NOTE' on a separate leaflet.

### 1.3 Soldering Hints :

1- Mount the component against the PCB surface and carefully solder the leads

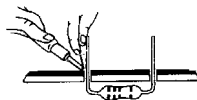

2- Make sure the solder joints are cone-shaped and shiny

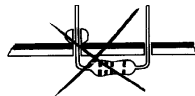
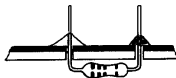

3- Trim excess leads as close as possible to the solder joint



REMOVE THEM FROM THE TAPE ONE AT A TIME !

**AXIAL COMPONENTS ARE TAPED IN THE  
CORRECT MOUNTING SEQUENCE !**

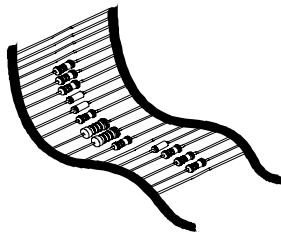

### 1. Resistors

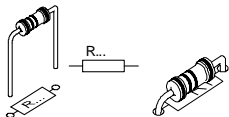

- R4 : 4K7 (4 - 7 - 2 - B)
- R5 : 10K (1 - 0 - 3 - B)
- R6 : 3K9 (3 - 9 - 2 - B)
- R7 : 220 (2 - 2 - 1 - B - 9)

### 3. Zenerdiodes Watch the polarity !

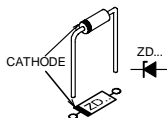

- ZD1 : 8V2
- ZD2 : 8V2
- ZD3 : 8V2

### 2. Diodes. Watch the polarity !

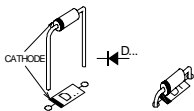

- D1: 1N4007
- D2: 1N4007
- D3: 1N4007
- D4: 1N4007
- D5: 1N4148

### 4. LED. Watch the polarity!

- LD1 : 3mm (red)

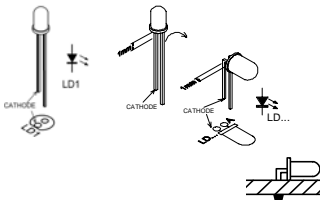

### 5. Ceramic Capacitor



### 6. 1W Resistor

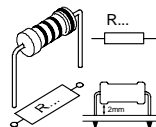

- R3 : 220 (2-2-1-B)

### 7. Pinheader

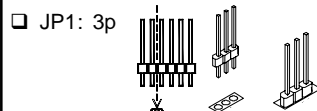

**8. Transistor**

- T1 : BC557B

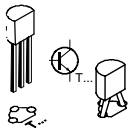

**9. 1/2W Resistors.**  
(Check the color code & mount them vertical)

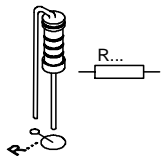

- R1 : 220K (2 - 2 - 4 - B - 9)  
 R2 : 220K (2 - 2 - 4 - B - 9)

**10. Electrolytic Capacitors.**  
Watch the polarity !

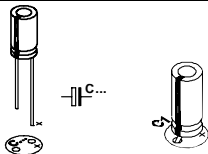

- C2 : 100 $\mu$ F / 35V

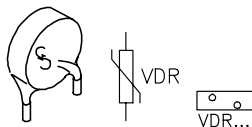
**11. VDR**

- VDR1 : VDR300

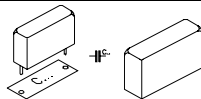
**12. Capacitor**

- C4 : 100nF/250V

**Depending operating voltage :**

- For 220 - 245VAC :  
C1 : 470nF/630V  
 For 110 - 125VAC :  
C1 : 1 $\mu$ F/250VAC

**13. Relay**

- RY1 : VR10V241C

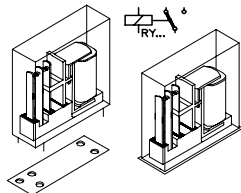

## 14. Shunt

The unit is equipped with a transient suppressor to reduce sparking. Normally, this suppressor is put over the relay contacts. In some cases it might be necessary to put it on the load (eg. with very small loads).

### Relay (2-3)

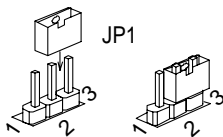

### Load (1-2)

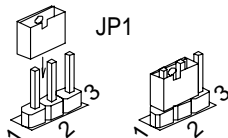

15. Application example

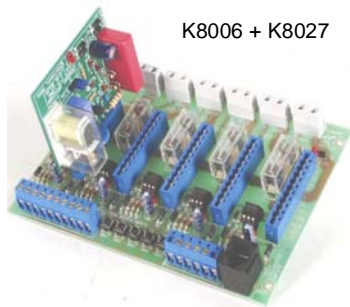

K8006 + K8027

K8046



K8045

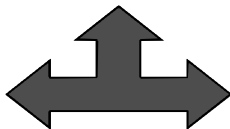

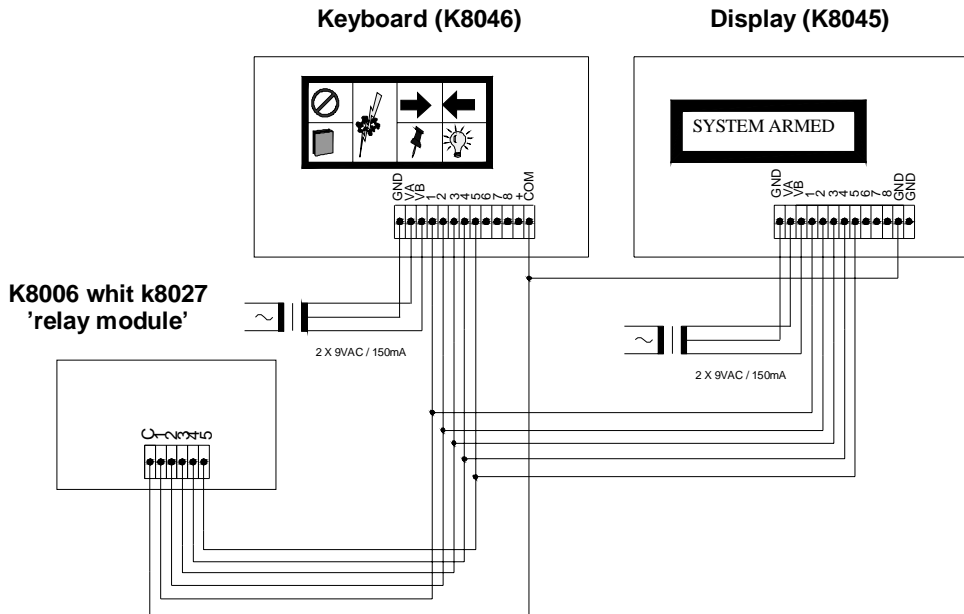



PCB

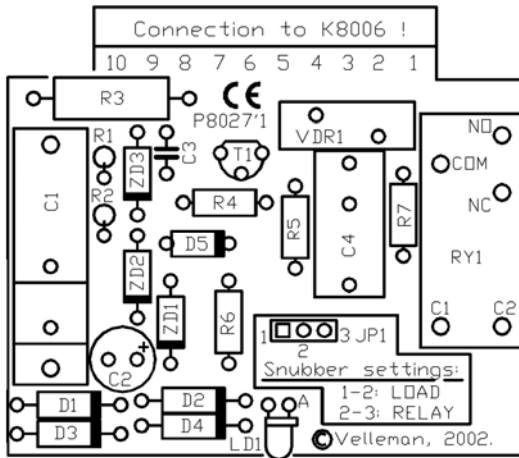



Modifications and typographical errors reserved  
© Velleman Components nv.  
H8027IP'1 (rev.1) - 2008

